



MK110-8D.4R

**Digital I/O-Module
12 channel**

8 DI, 4 DO

User guide

Contents

1	Description	2
1.1	Function	2
1.2	Counter Function	2
1.3	RS485 network	2
1.4	Design.....	3
2	Specifications	4
2.1	Environmental conditions.....	4
3	Safety	5
3.1	Safety symbols and key words	5
3.2	Intended use	5
4	Installation	6
4.1	Wiring.....	6
4.1.1	Hardware write protection.....	6
4.1.2	Inputs	7
4.1.3	Outputs	7
5	Configuration	9
6	Operation	11
6.1	Functional test	11
6.2	Input/Counter Status.....	11
6.3	Individual ON/OFF control	11
6.4	Individual control in PWM mode	11
6.5	Group control	12
6.6	Fault condition	12
6.7	Memory addressing	12
7	Logic Connections	14
7.1	Parameter logic.....	14
7.2	Delay Type Parameter.....	14
7.3	Delay Parameter.....	14
7.4	Time Diagram and Distribution	15
8	Factory Settings Restoration	18
9	Maintenance	20
10	Transportation and storage	21
11	Scope of delivery	22
Appendix A	Dimensions	23

Description

1 Description

1.1 Function

Digital input/output module MK110-24.8D.4R is an expansion module with 8 digital inputs and 4 digital outputs.

The module functions as follows:

- Connection of peripherals with digital outputs
- Digital signal processing
- Pulse counter (refer to 1.2)
- Connection of actuators with digital inputs
- Control of digital outputs (via RS485 network or with internal logic)
- Pulse-width modulation (refer to 6.4)
- Diagnostics of RS485 Network status
- Generation of the appropriate error signals or alarm signals
- Slave device in Modbus protocol structure

The module supports Modbus-RTU and Modbus-ASCII protocols and is equipped with automatic protocol identification.

The module is to be configured using 'M110 Configurator' software (included on CD) via RS485-USB interface adapter IC4 (not included). The latest version of the configuration software is available for download on www.akytec.de.

1.2 Counter Function

Additionally the module can use all inputs as fast 16-bit counter with operating counting frequency up to 1 kHz. Minimum one-pulse time is 0.5 ms. Pulses with higher frequency or less one-pulse time are ignored. The counter responses on rising edge.

When switching off the counter status is saved in the long-term memory.

In case of full filling the counter is reset to zero and counting continues.

Function of debouncing can be activated for each input. For this purpose during configuration parameter **tin.c** (debouncing filter) shall be set to "On" (refer to Table 5.1). It is recommended to use this function at signal frequency up to 90 Hz and duty ratio 50% and more.

1.3 RS485 network

I/O modules of Mx110 series uses common standard RS485 to exchange data. RS485 serial interface ensures communication via two-wire line in half-duplex mode. The modules support protocols Modbus RTU, Modbus ASCII and akYtec. The network consists of a host device and can have up to 32 slave devices. Maximum length is 1,200 m. The number of slave de-vices and network length can be increased with interface extender RS485. Separate devices (slave devices) are connected according to linear (bus) topology. It means that the line goes from the first device to the second one, from the second one to the third one, etc. Star connection and interconnection tie lines are not allowed.

Line reflections always occur in open cable terminals (the first and the last nodes in the bus-bar). The higher the chosen data transmission rate, the stronger they are. A terminating resistor is provided to keep reflections at minimum possible level. Experience proved that it is the most efficient to provide for terminating resistors 150 ohm.

All modules are used only in slave mode. PLC, computers with SCADA software and control panel can be host devices.

Description

1.4 Design

- Enclosure: plastic, grey, for wall mounting or mounting on DIN-rail
- Terminal blocks: 2 plug-in terminal blocks with 24 screw terminals
- LED “POWER” power supply
- LED “RS-485” flashes in case of data exchange via serial port
- LED “FAULT” is on if data exchange via serial port is terminated
- 8 LEDs “INPUTS” are on in case of logical 1 in the appropriate input
- 4 LEDs “OUTPUTS” are on in case of logical 1 at the appropriate output

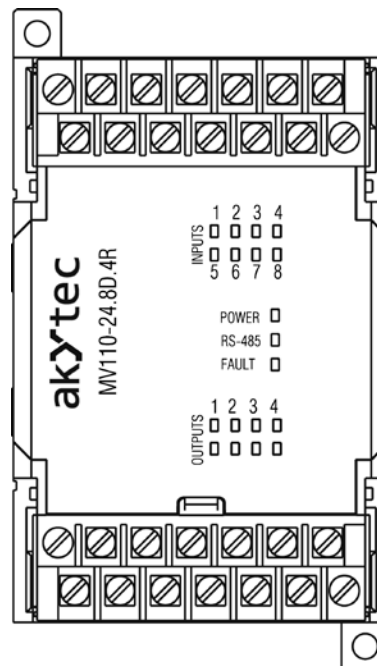

Fig. 1.1 Front View

Dimensional Sketches are given in Appendix A.

Under the cover on the front panel of the module three jumpers are located (refer to Fig. 4.1):

- X2 Factory settings restoration (refer to 8)
- X3 Service function
- X1 Hardware protection from long-term memory writing

All 3 jumpers are not enabled during delivery.

Specifications

2 Specifications

Table 2.1 General specifications

Power supply		24 (20...28) V DC
Power consumption, max.		6 W
Inputs	digital	8
	analog	
Outputs	digital	4
	analog	-
	Permissible load	4 A, 250 V AC $\cos\phi > 0.4$ or 24 V DC
RS485 interface	Terminals	D+, D-
	Protocols	Modbus RTU/ASCII, akYtec
	Baud rate	2.4...115.2 kbit/s
	Data bits	7, 8
	Parity	even, odd, none
	Stop bits	1, 2
Dimensions		63 x 110 x 75 mm
Weight		approx. 260 g
Material		plastic

Table 2.2 Input specifications

Type	Switching contact, NPN
Galvanic Isolation	-
Insulation strength	1500 V
Pulse frequency, max.	1 kHz
Pulse width, min.	0.5 ms
Current, max	7 mA
Line resistance, max.	100 ohm

2.1 Environmental conditions

The module is designed for natural convection cooling. It should be taken into account when choosing the installation site.

The following environment conditions must be observed:

- clean, dry and controlled environment, low dust level
- closed non-hazardous areas, free of corrosive or flammable gases

Table 2.3 Environmental conditions





Condition	Permissible range
Ambient temperature	-20...+55°C
Transportation and storage	-25...+55°C
Relative humidity	up to 80% (at +25°C, non-condensing)
IP code	IP20
Altitude	up to 2000 m above sea level

Safety

3 Safety

3.1 Safety symbols and key words

Explanation of the symbols and keywords used:

 DANGER	<p><i>DANGER indicates an imminently hazardous situation which, if not avoided, will result in death or serious injury.</i></p>
 WARNING	<p><i>WARNING indicates a potentially hazardous situation which, if not avoided, could result in death or serious injury.</i></p>
 CAUTION	<p><i>CAUTION indicates a potentially hazardous situation which, if not avoided, could result in minor or moderate injury.</i></p>
 NOTICE	<p><i>NOTICE indicates a potentially harmful situation which, if not avoided, may result in damage of the product itself or of adjacent objects.</i></p>

3.2 Intended use

The device is provided only for the areas of application described in the user guide when all indicated specifications are observed.

The module can be used only according to the data given in the specification.

Improper use:

- The module may not be used for medical appliances applied to maintain human life or health, its control or other effect on them.
- The module may not be used in explosive environment.
- The module may not be used in atmosphere in which there are chemically active substances.

4 Installation



WARNING

Improper installation

Improper installation can cause serious or minor injuries or device damage. Installation must be performed only by fully qualified personnel

- The module is intended to be installed in the housing on DIN-rail or on the wall.
- Install the module in the housing with clean, dry and controllable environment. Further requirements are specified in 2.3.
- The module is designed for convective self-cooling. It should be taken into account when the installation place is chosen.

4.1 Wiring



DANGER

Dangerous voltage

Electric shock could kill or seriously injure.

All electrical connections must be performed by a fully qualified electrician.

Ensure that the mains voltage matches the voltage marked on the nameplate!

Ensure that the device is provided with its own power supply line and electric fuse!



NOTICE

Switch on the power supply only after wiring of the device has been completed.

- Electrical connections are given in Fig. 4.1, and terminal arrangement is given in Table 4.1.
- Connection variants for various types of signals and connection of output relays are given in Fig. 4.2 – 4.4.
- Connect the power supply to the terminals 24 V / 0 V.
- Cross section in the connection place $\leq 1.5 \text{ mm}^2$.



NOTICE

EMC safety

Signal cables should be routed separately or screened from the supply cables.

Only shielded cable can be used for the signal lines.

It is strongly recommended to connect the screen in the electrical cabinet in accordance with EMC requirements.

- Connect the RS485 lines to the terminals D(+) and D(-).
- Twisted pair cable should be used for the connection to RS485 interface. Maximal cable length is 1200 m.

4.1.1 Hardware write protection

In case of strong electromagnetic interferences or similar condition data in the long-term memory can be lost.

Jumper X1 (hardware protection of writing) allowed avoiding data loss.

The following steps shall be performed:

- Turn the power supply off
- Open the front cover of the module (see Fig. 4.1)
- Place jumper X1 in closed position

Notice following:

- In order to change configuration parameters X1 jumper shall be removed again
- Till X1 jumper is installed, at power off input counters will be reset.

Installation

4.1.2 Inputs

The following can be connected at input:

- Switch contacts
- NPN transistor outputs with open collector

Pay attention to the following during connection:

- All COM terminals are connected between each other.
- Total resistance of the sensor output with connection lines shall not exceed 100 ohm.

4.1.3 Outputs

The module is equipped with 4 relay outputs.

- DO1, DO3 – switching contact
- DO2, DO4 – relay (NO)
- Each output can be used in pulse-width modulation mode (refer to 6.4).

Outputs can be controlled via RS485 network (refer to 6.3 - 6.5) or they can be logically connected with inputs (refer to 7).

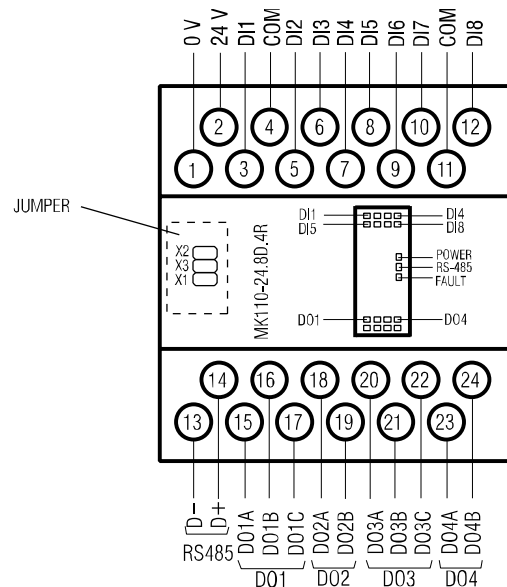

Fig. 4.1 Electrical connections

Table 4.1 Terminal assignments

No	Designation	Description	No	Designation	Description
1	0 V	Power Supply	13	D-	RS485 D/-
2	24 V	Power Supply	14	D+	RS485 D/+
3	DI1	DI1	15	DO1A	DO1 NO
4	COM	Common negative terminal	16	DO1B	DO1 CO
5	DI2	DI2	17	DO1C	DO1 NC
6	DI3	DI3	18	DO2A	DO2 NO
7	DI4	DI4	19	DO2B	
8	DI5	DI5	20	DO3A	DO3 NO
9	DI6	DI6	21	DO3B	DO3 CO
10	DI7	DI7	22	DO3C	DO3 NC
11	COM	Common negative terminal	23	DO4A	DO4 NO
12	DI8	DI8	24	DO4B	

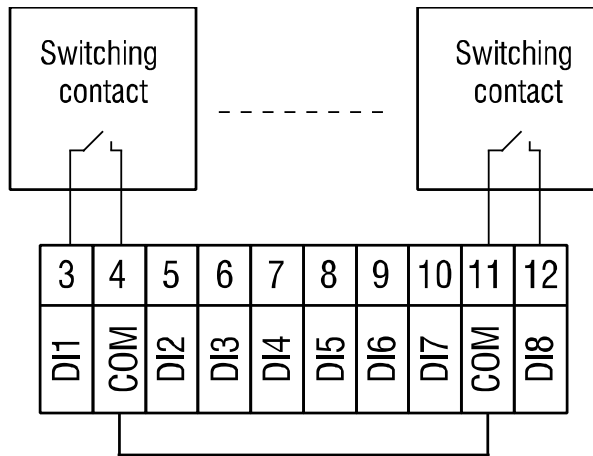

Fig. 4.2 Connection of switch contacts

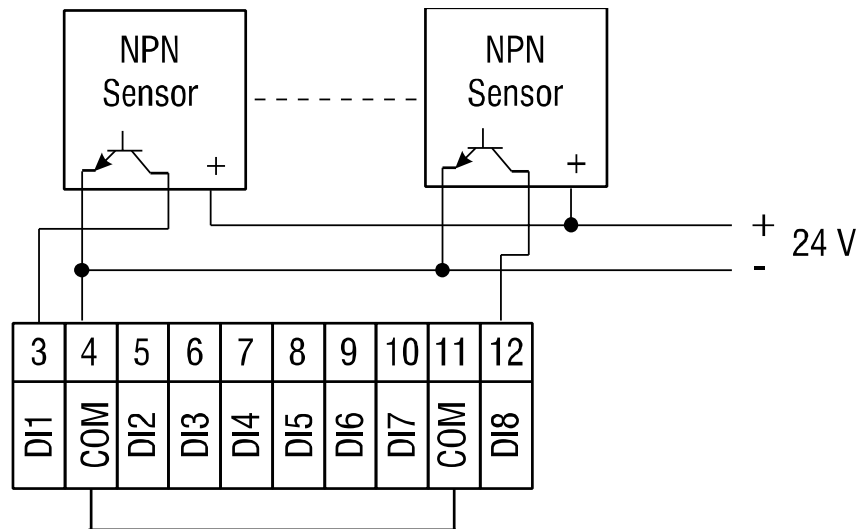

Fig. 4.3 Connection of 3-wire sensors with PNP-transistor output

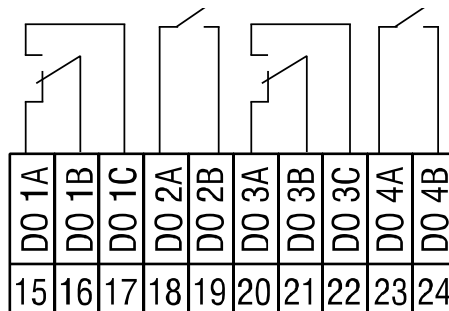

Fig. 4.4 Relay outputs

Configuration

5 Configuration

► NOTICE

Before starting

Before switching on, make sure that the device was stored at the specified ambient temperature (-20 ... +55 °C) for at least 30 minutes.

Parameters of the module can be read, edited and saved with 'M110 Configurator' software. The full list of parameters is shown in the Table 5.1.

The software and its user guide can be found on the CD included.

Module has to be configured first before operating in RS485 network.

The following steps are required:

- Install M110 Configurator on the PC.
- Connect the module to the USB interface of the PC over RS485-USB interface adapter IC4 (not included). Connect the D+/D- terminals of the module with the D+/D- contacts of the adapter.
- Connect the power supply to 24V/0V terminals of the module.
- Turn on the power supply.
- Run the Mx110 Configurator.

If the factory settings of the module have not been changed, the connection to the module is automatically established, the module automatically recognized, its configuration parameters read out and an appropriate configuration mask open.

If it does not happen, parameters of the configurator have to be changed.

Table 5.1 Configuration parameters

Name	Parameter	Valid value	Meaning	Default setting
Basic parameters				
dev	Device	up to 8 characters		MK110-8D4R
ver	Firmware version	up to 8 characters		Manufacturer
Network parameters				
bPS	Baud rate, kbit/s	0	2.4	9.6
		1	4.8	
		2	9.6	
		3	14.4	
		4	19.2	
		5	28.8	
		6	38.4	
		7	57.6	
LEn	Data bits *	0	7	8
		1	8	
PrtY	Parity *	0	none	none
		1	even	
		2	odd	
Sbit	Stop bits *	0	1	1
		1	2	
A.Len	Address bits	0	8	8
		1	11	
Addr	Device address	1...247		16

Configuration

Name	Parameter	Valid value	Meaning	Default setting
t.out	Time-out, s	0...600		0
Rs.dL	Response delay, ms	0...45		2
Input parameters				
Tin.C	Debouncing filter	0	off	0
		1	on	
Output parameters				
THPD	PWM period, s	1...900	1...900	1
O.ALr	Safe output status, %	0...100	0...100	0
Log	Output logic	0	RS485	0
		1	direct logic	
		2	NOT	
		3	AND	
		4	OR	
		5	one impulse	
		6	PWM	
		7	trigger	
O.dl	On/Off-delay	0	no delay	0
		1	on-delay	
		2	off-delay	
Tim	Output_delay,_x0.1s	0...65535	x 0.1 s	0

* Invalid network parameter combinations:

- *prty=0; sbit=0; len=0*
- *prty=1; sbit=1; len=1*
- *prty=2; sbit=1; len=1*

Operation

6 Operation

In the operation mode the module is controlled by a network Master in Modbus network. It can be performed in different ways:

- Individual control in digital mode (see to 6.3)
- Individual control in PWM mode (see to 6.4)
- Group control (see to 6.5)

Modbus functions 03, 04 for reading and 15, 16 for writing can be used.

6.1 Functional test

To check functioning of module MK110-24.8D.4R the following steps shall be performed:

- Connect the module to USB-port of the PC using a USB/RS485 adapter.
- Run M110 Configurator on the PC.
- If the connection has not been established automatically, the network parameters of the configurator have to be changed.
- Choose menu item ‘Device -> I/O status...’. A new window “Output status” will open.
- For each output the PWM duty cycle (pulse to period ratio) between 0 and 1 can be set, so that output is switched on/off or a continuous pulse train is generated.
- Output resistance for MK110-8D.4R modification can be optionally measured with an ohmmeter.
- Max resistance on closed outputs – 1 ohm.
- Min resistance on open outputs – 2 Mohm.
- If there are any deficiencies in functioning, contact technical support of akYtec GmbH.

6.2 Input/Counter Status

Input status can be read out as bit mask. The appropriate Modbus registers are given in Table 6.2. The least significant bit of the mask corresponds to input 1.

To reset the counter in the appropriate register 0 shall be specified.

6.3 Individual ON/OFF control

Using function Modbus 15 (0x0F) "Write Multiple Coils" the certain number of outputs can be controlled. The command shall include the following:

- Start address (0x0000 to 0x0003)
- Number of described bits (0x0001 to 0x0004)
- Byte number n (0x01)
- Information (bit mask, n bytes)

Addressing of separate cells is given in Table 6.3.

6.4 Individual control in PWM mode

Using pulse-width modulation average value of voltage can be changed. Pulses with the specified repetition period (thpd) and duty ratio (ratio between one-pulse time and its repetition period) will be generated sequentially via output.

Output status depending on entered duty ratio is given in Table 6.1. Function 16 is used for writing.

Operation

Table 6.1 Pulse width modulation

Duty cycle		Output status
Configuration	Modbus command	
0	0	0
1	1000	1
between 0 and 1	between 0 and 1000	Pulses with duty ratio between 0 and 100%

The PWM period (**THPD**) is usually set during the configuration. The period can also be changed by a Modbus command, and the following should be noted:

Parameter 'Duty cycle'

► NOTICE

The configurator uses not the Modbus protocol but its own internal communication protocol. Therefore, range of value in configuration and in Modbus command can differ. For example, the duty cycle must be set to 1 for switching on the output DO1 during the functioning test. In a Modbus command the duty cycle must be written as 0001 in register 0000.

Permanent memory

► NOTICE

As the permanent memory is not unlimited rewritable (approx. 10^6 times), it is not advisable to change the parameters 'THPD (PWM period) and 'O.ALr' (Safe output status) by Modbus commands as often as, for instance, PWM duty cycle.

Minimum period of pulse-width modulation is 50 ms and can't be changed.

6.5 Group control

Group control is performed using Modbus function 16. Thus the output status bitmask (see Tab. 6.2) has to be written into the register 50 (0x0032). This way all outputs can be controlled simultaneously. Bit 0 corresponds to the output 1.

With the transfer of the mask the generation of the pulse is stopped and the outputs are set in accordance with the mask.

6.6 Fault condition

If the data exchange on the serial port is interrupted (i. e. there is no command from the master within the time specified by the parameter **t.out**) all outputs are set to a safe status. The 'Fault Condition' is a combination of all safe PWM duty cycle values, set in parameter **O.ALr** (Safe output status) for each output.

In this condition the following applies:

- LED "FAULT" is on.
- As soon as a query is received from the host device, indication is off.
- Outputs remain in safe status, until the command about status change is received from the host device.
- If **t.out** parameter is set to 0, then fault status doesn't occur.

Parameters **t.out** and **O.ALr** can be set during configuration or operation as well. The note 'Permanent memory' in sec. 6.3 should be taken into account.

6.7 Memory addressing

All variables and parameters in Table 6.2 are specified for type uint16.

Variables in Table 6.3 are specified for type bool

R – access to readout

W – access to write

Operation

Table 6.2 Modbus register

Parameter	Unit	Value		Access	Address	
		Configuration	Modbus-Command		hex	dec
Duty cycle DO1	-	0...1	0...1000	RW	0000	0000
Duty cycle DO2	-	0...1	0...1000	RW	0001	0001
Duty cycle DO3	-	0...1	0...1000	RW	0002	0002
Duty cycle DO4	-	0...1	0...1000	RW	0003	0003
Safe output status (O.ALr) DO1	-	0...100	0...1000	RW	0010	0016
Safe output status (O.ALr) DO2	-	0...100	0...1000	RW	0011	0017
Safe output status (O.ALr) DO3	-	0...100	0...1000	RW	0012	0018
Safe output status (O.ALr) DO4	-	0...100	0...1000	RW	0013	0019
PWM period (THPD) DO1	s	1...900	1...900	RW	0020	0032
PWM period (THPD) DO2	s	1...900	1...900	RW	0021	0033
PWM period (THPD) DO3	s	1...900	1...900	RW	0022	0034
PWM period (THPD) DO4	s	1...900	1...900	RW	0023	0035
Time-out (t.out)	s	0...600	0...600	RW	0030	0048
Bit mask of output status	-	-	0...15	RW	0032	0050
Bit mask of input status	-	-	0...255	R	0033	0051
Counter DI1	-	0...65535	0...65535	RW	0040	0064
Counter DI2	-	0...65535	0...65535	RW	0041	0065
Counter DI...	-	0...65535	0...65535	RW
Counter DI8	-	0...65535	0...65535	RW	0047	0071
Logic DO1 (Log)	-	0...7	0...7	RW	0050	0080
Logic DO2 (Log)	-	0...7	0...7	RW	0051	0081
Logic DO3 (Log)	-	0...7	0...7	RW	0052	0082
Logic DO4 (Log)	-	0...7	0...7	RW	0053	0083
Delay type DO1 (O.dl)	-	0...2	0...2	RW	0060	0096
Delay type DO2 (O.dl)	-	0...2	0...2	RW	0061	0097
Delay type DO3 (O.dl)	-	0...2	0...2	RW	0062	0098
Delay type DO4 (O.dl)	-	0...2	0...2	RW	0063	0099
Delay DO1 (Tim)	0.1 s	0...65535	0...65535	RW	0070	0112
Delay DO2 (Tim)	0.1 s	0...65535	0...65535	RW	0071	0113
Delay DO3 (Tim)	0.1 s	0...65535	0...65535	RW	0072	0114
Delay DO4 (Tim)	0.1 s	0...65535	0...65535	RW	0073	0115

Table 6.3 Output status binary addresses for Modbus function 15

Output	Access	Address	
		hex	dec
DO1	W	0000	0000
DO2	W	0001	0001
DO3	W	0002	0002
DO4	W	0003	0003

7 Logic Connections

As soon as for any output parameter Logic (**Log**) is not equal to 0, then its control by the host device is terminated. The output status depends on parameters Logic (**Log**), Delay Type (**O.dl**) and Delay (**Tim**). The parameters are set during configuration (refer to 5). Time diagram and I/O distribution are given in Tables 7.4, 7.5. Readout function can be used further.

7.1 Parameter logic

In output parameter Logic (**log**) logic connections between inputs and outputs are established.

Table 7.1 Parameter **log**

No.	Value	Description
0	RS485	Output is controlled by the host device
1	direct logic	Direct connection between output and input
2	NOT	Inverted connection between output and input
3	AND	Two inputs are connected with output by logic "AND"
4	OR	Two inputs are connected with output by logic "OR"
5	one impulse	When rising edge at input, at output pulse with length specified in parameter Tim is generated.
6	PWM	At activated input, at output pulses with repetition period THPD and length Tim are generated continuously
7	trigger	If DIa=1 and DIb=0, then DO=1 If DIb=1, then DO=0

Till parameter Time-out (**t.out**) > 0 is used and fault status is indicated (refer to 6.6), outputs with log > 0 will not be set to "Safe output status" (**O.ALr**). Output status will be determined by the selected logic further.

7.2 Delay Type Parameter

Parameter Delay Type (**O.dl**) determines, whether delay occurs and the delay type.

Table 7.2 Parameter **O.dl**

No.	Value	Description
0	no delay	Without delay
1	on-delay	Delay during activation
2	off-delay	Delay during deactivation

7.3 Delay Parameter

Parameter Delay (**Tim**) determined delay at output or pulse length depending on logic (**Log**) and delay type (**O.dl**). Delay value can be entered within the range from 0 to 6553.5 s with increment 0.1 s.

Table 7.3 Delay Influence

log	o.dl=0	o.dl=1	o.dl=2
0	-	-	-
1	-	Delay during activation	Delay during deactivation
2	-	Delay during activation	Delay during deactivation
3	-	Delay during activation	Delay during deactivation
4	-	Delay during activation	Delay during deactivation
5	-	Pulse length	Pulse length
6	-	Pulse length	Pulse length
7	-	-	-

7.4 Time Diagram and Distribution
Table 7.4 Time Diagram

Log		O.dl		
No.	Value	0 (no delay)	1 (on-delay)	2 (off-delay)
1	direct logic			
2	NOT			
3	AND			
4	OR			
5	one impuls		Not used	Not used
6	PWM		Not used	Not used
7	trigger		Not used	Not used

If DIa=1 and DIb=0,
then DO=1
If DIb=1, then DO=0

Logic Connections

Table 7.5 I/O Distribution

Log		Distribution
No.	Value	
1	direct logic	
2	NOT	
3	AND	
4	OR	
5	one impuls	
6	PWM	

Logic Connections

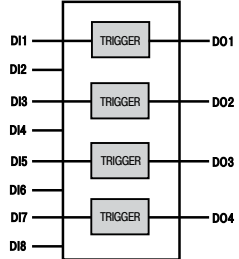
Log		Distribution
No.	Value	
7	trigger	

Factory Settings Restoration

8 Factory Settings Restoration

If communication between the computer and the module is not established, and network parameters of the module are unknown, then for network parameters factory settings shall be restored. The following steps shall be performed:

- Power off the module.
- Remove cover on the front panel of the module.
- Install X2 jumper. The module will operate with network parameters set by the manufacturer, user's settings are saved.
- Power on again.



Dangerous voltage

The voltage on some components of the circuit board can be dangerous! Direct contact with the circuit board or penetration of a foreign body in the enclosure must be avoided!

- Start configuration program "M110 Configurator".
- Enter value from Table 8.1 in window "Connect Device" or press button "Use factory settings" (refer to Fig. 8.1).

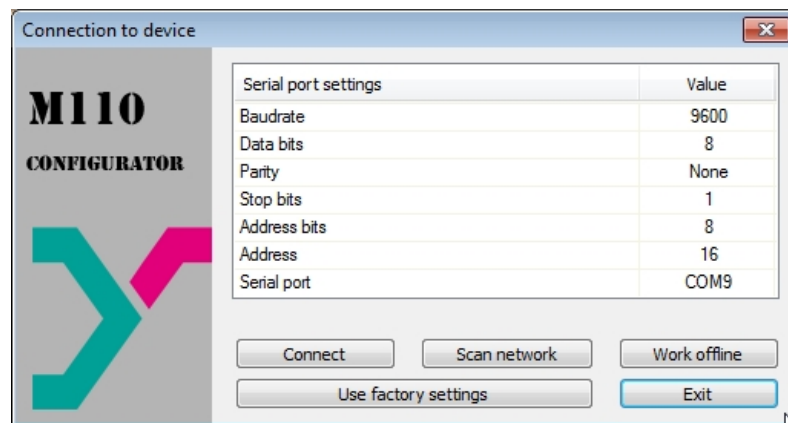

Fig. 8.1 M110 Configurator start window

- Press button "Connect". Connection will be established with factory network parameters.
- Main window of the configurator is opened. Now saved parameters of the module can be read out (refer to Figure 8.2).
- Open folder "Network parameters" in the main window of "M110 Configurator" and write values of the network parameters

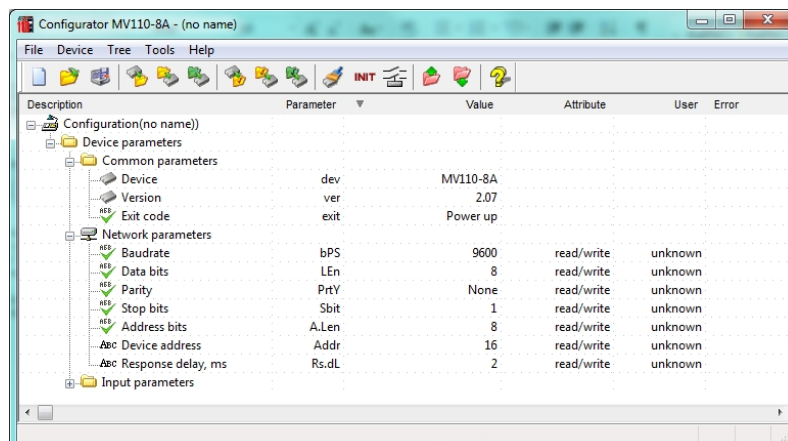

Fig. 8.2 M110 Configurator main window

Factory Settings Restoration

- Close "M110 Configurator"
- Turn off the power supply
- Remove X2 jumper
- Install the cover
- Turn on the power supply
- Restart "M110 Configurator"
- Enter the written network parameters
- Press button "Connect".

The module is ready for operation.

Table 8.1 Factory settings for network parameters

Parameter	Name	Factory setting
Baud rate	bPS	9600
Data bits	LEn	8
Parity	PrtY	none
Stop bits	Sbit	1
Address bits	A.Len	8
Address	Addr	16
Response delay, ms	Rs.dL	2

Maintenance

9 Maintenance

The maintenance includes:

- cleaning of the housing and terminal blocks from dust, dirt and debris
- checking the fastening of the device
- checking the wiring (connecting leads, fastenings, mechanical damage).

The device should be cleaned with a damp cloth only. No abrasives or solvent-containing cleaners may be used. The safety information in section 3 must be observed when carrying out maintenance.

Transportation and storage

10 Transportation and storage

Pack the device in such a way as to protect it reliably against impact for storage and transportation. The original packaging provides optimum protection.

If the device is not taken immediately after delivery into operation, it must be carefully stored at a protected location. The device should not be stored in an atmosphere with chemically active substances.

Permitted storage temperature: -25...+55 °C

▶ NOTICE

Transport damage, completeness

The device may have been damaged during transportation.

Check the device for transport damage and completeness!

Report the transport damage immediately to the shipper and akYtec GmbH!

Scope of delivery

11 Scope of delivery

- | | |
|--------------------------------------|---|
| – Module MK110-24.8D.4R | 1 |
| – User guide | 1 |
| – CD with software and documentation | 1 |

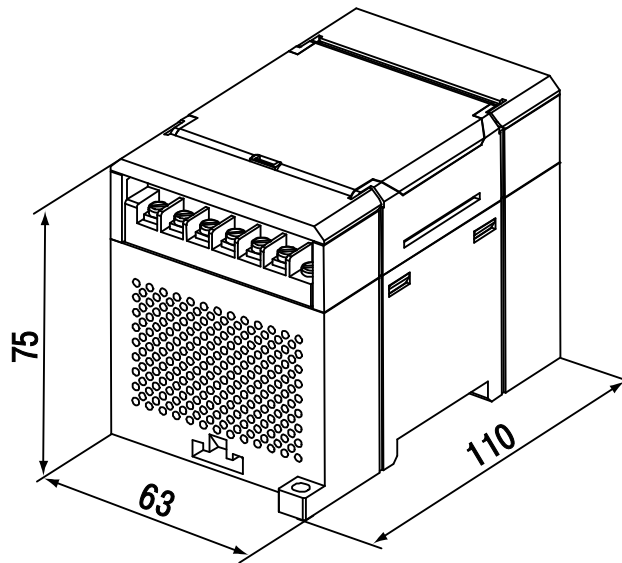

Fig. A.1 External dimensions

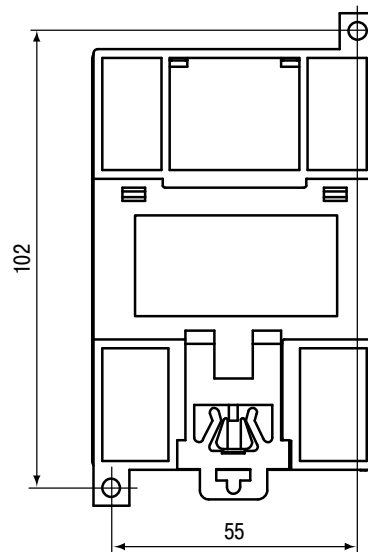

Fig. A.2 Wall mounting dimensions

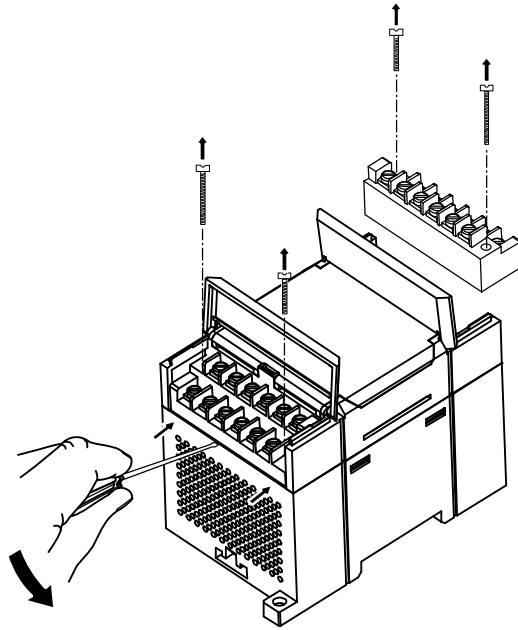

Fig. A.3 Replacement of terminal blocks