

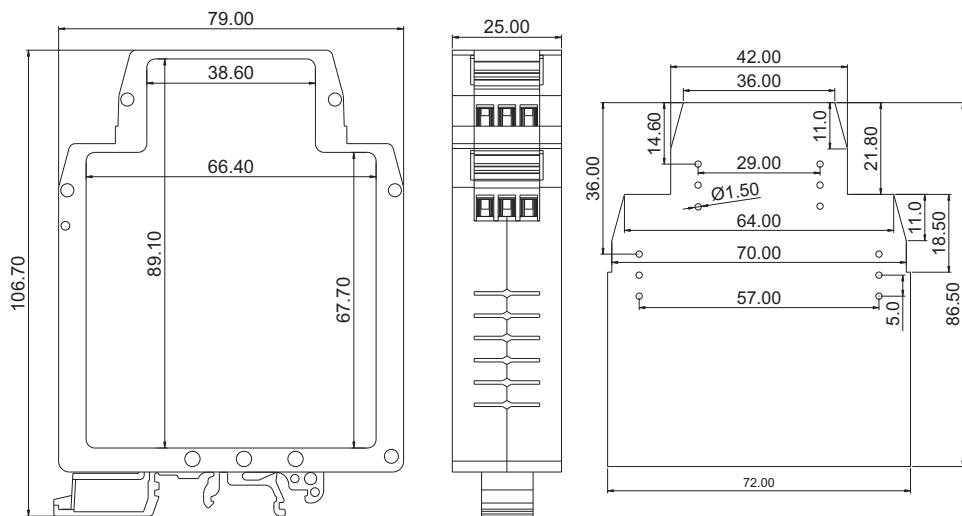

慈溪三和电器塑料有限公司

CIXI SNAHE APPLIANCE & PLASTICS CO., LTD.

产品规格书



认证		
电气性能		
参考标准	UL	IEC
额定电压	300V	250V
额定电流	9A	12A
使用线径	24-14AWG	2.5mm ²
耐电压	AC2500V/Min	
机械性能		
温度范围	-40℃~+105℃	
剥线长度	6-7mm	
扭距	4.0kgf.cm	
尺寸		
间距	5.0mm	
极数	3P	
材质及电镀		
塑件	Pa66 UL94V-0	
方块	黄铜 镀镍	
焊脚	黄铜 镀锡	
螺丝	M3 铁 镀镍	

订购方式:

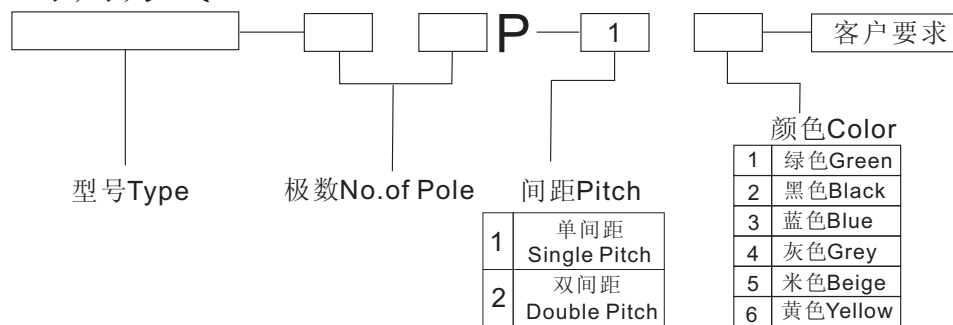

MM (INCH) 慈溪三和电器塑料有限公司
CIXI SNAHE APPLIANCE & PLASTICS CO., LTD.

THIRD ANGLE PROJECTION NAME SH803-25