

IST-23xx Integrated Stepper Motor

Motor + Drive, 18-50VDC, NEMA23, 0.9-2.0Nm



Features

- Integrated compact size for saving mounting space & setup time, and reducing electrical interference
- Anti-Resonance provides optimal torque and nulls mid-range instability
- Motor auto-identification and parameter auto-configuration technology
- Multi-Stepping allows a low resolution step input to produce a higher micro step output
- Smooth motor movement with no vibration
- Input voltage from 18 to 50 VDC (20-36VDC recommended)
- Motor current programmable, from 0.5A to 6.0A. It can also be set via DIP switches.
- 0.9-2.0Nm (126-285oz-in) holding torque stepper motor with NEMA 23 frame size installation
- 15 micro step resolution options via DIP switches; or any value from 200-51,200 (increased by 1) via software configuration
- Soft-start with no “jump” when powered on
- Automatic idle-current reduction (Reduction rate can be software configured)
- Isolated control inputs of Pulse, Direction and Enable
- Pulse input frequency can be 200K or 500K (Software-configured)
- Pulse input mode can be PUL/DIR or CW/CCW (Software-configured)
- Fault outputs to external motion controllers for complete system controls.
- Over voltage and over-current protection

Descriptions

Leadshine’s iST-23xx integrated stepper is a NEMA 23 stepper motor integrated with an advanced DSP stepper drive. At very compact size and with all components integrated, the iST-23xx can save mounting space, eliminate motor wiring time, reduce interference, and cut/reduce cable and labor costs. By adopting Leadshine’s latest current control technology, the drive of the iST-23xx can drive the stepper motor with high precision, smooth movement, and extra low noise at low speed movement with no obvious resonance area.

Applications

Leadshine’s iST-23xx can be used in various applications such as laser cutters, laser markers, high precision X-Y tables, labeling machines, CNC router, etc. Its unique features make the iST-23xx an ideal choice for applications that require both low-speed smoothness and small mounting space.

Specifications

Electrical Specifications of Drive

Parameter	Min	Typical	Max	Unit
Input Voltage	18	36	50	VDC
Output Current	0.5	4.8(Peak)	6.0(Peak)	A
Pulse Input Frequency	0	200	500	kHz
Pulse Voltage	3.3	5	24	V
Logic Signal Current	7	10	16	mA
Isolation Resistance	100	-	-	MΩ

Operating Environment

Cooling	Natural Cooling or Forced cooling	
Operating Environment	Environment	Avoid dust, oil fog and corrosive gases
	Ambient Temperature	0°C — 40°C (32°F — 104°F)
	Humidity	40%RH — 90%RH
	Operating Temperature (Heat Sink)	70°C (158°F) Max
Storage Temperature	-20°C — 65°C (-4°F — 149°F)	

Mechanical Specifications

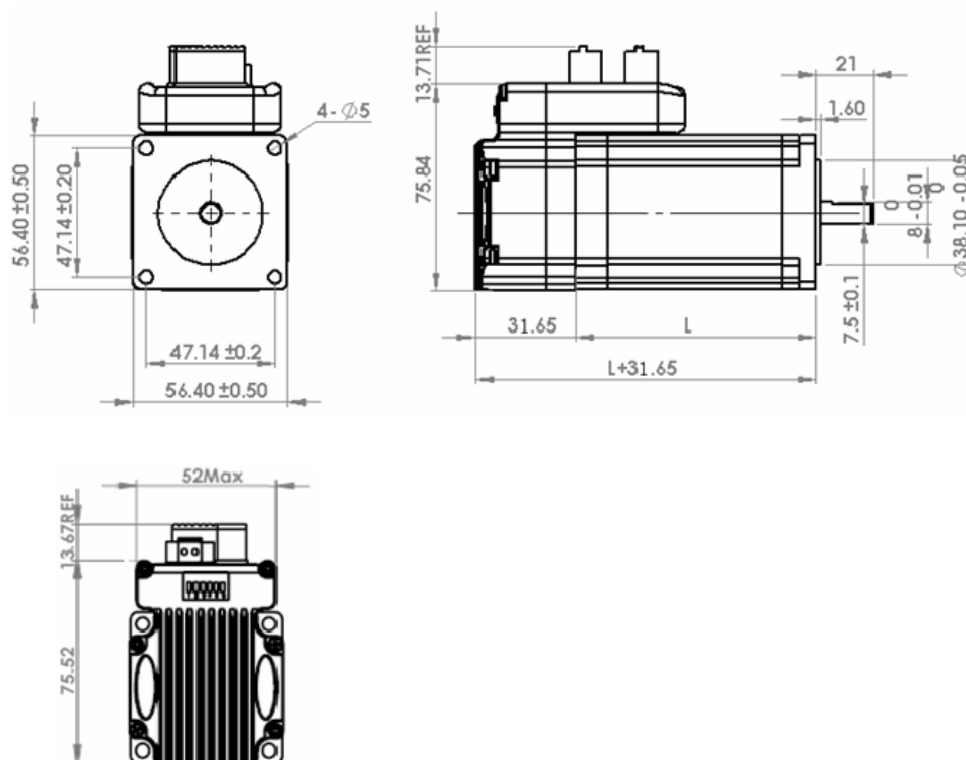



Mechanical Specifications (Continued)

Part Number	Holding Torque	Motor Length (L)	Length of Motor + Drive	Weight
iST-2309	0.9Nm	56mm	87.65mm	0.84kg
iST-2320	2.0Nm	80mm	111.65mm	1.25

Protection Indications

The green light turns on when the iST-23xx is powered on and functions normally. In any case that drive protection is activated, the red LED blinks periodically (in every 4 seconds) to indicate the error type. In each blink, red light is on for 0.2 second and then off for 0.3 second.

Priority	Time(s) of Blink	Sequence wave of red LED	Description
1st	1		Over-current protection activated when peak current is greater than 18A
2nd	2		Over-voltage protection activated when drive working voltage is greater than 60±2 VDC

Connectors and Pin Assignment

Leadshine's iST-23xx has three connectors, a connector for power connections, a connector for control signals connections and a connector for RS232 communication connections.

Power Connector			
Pin	Name	I/O	Description
1	+Vdc	I	Power Supply Input (Positive) 20-36VDC recommended, leaving reasonable reservation for voltage fluctuation and back-EMF during deceleration.
2	GND	GND	Power Ground (Negative)

Connectors and Pin Assignment (Continued)

Control Signal Connector			
Pin	Name	I/O	Description
1	PUL+	I	<u>Pulse signal</u> : In single pulse (pulse/direction) mode, this input represents pulse signal, active at each rising or falling edge (software configurable). In double pulse mode (software configurable), this input represents clockwise (CW) pulse, active both at each high level and low level. 4.5-24V for PUL-HIGH, 0-0.5V for PUL-LOW. For reliable response, pulse width should be longer than 2.5 μ s for 200K MAX input frequency or 1 μ s for 500K MAX input frequency.
2	PUL-	I	
3	DIR+	I	<u>Direction Signal</u> : In single-pulse mode, this signal has low/high voltage levels, representing two directions of motor rotation. In double-pulse mode (software configurable), this signal is counter-clock (CCW) pulse, active both at high level and low level. For reliable motion response, DIR signal should be ahead of PUL signal by 5 μ s at least. 4.5-24V for DIR-HIGH, 0-0.5V for DIR-LOW. The motor direction can also be changed by DIP switch S5.
4	DIR-	I	
5	ENA+	I	<u>Enable signal</u> : This signal is used for enabling/disabling the drive board. By default, high level (NPN control signal) for enabling the drive board and low level for disabling the drive board. It is usually left UNCONNECTED (ENABLED) . Please note that the PNP and Differential control signals are on the contrary, namely Low level for enabling. The active level of ENA signal is software configurable.
6	ENA-	I	
7	PED+	-	Not connected.
8	PED-	-	
9	ALM+	O	<u>Alarm Signal</u> : OC output signal, activated when one of the following protection is activated: over-voltage and over current error. They can sink or source MAX 20mA current at 24V. By default, the impedance between ALM+ and ALM- is low for normal operation and becomes high when any protection is activated. The active impedance of alarm signal is software configurable.
10	ALM-	O	

RS232 Communication Connector			
Pin	Name	I/O	Description
1	5V	O	+5V power output (Note: Do not connect it to PC's serial port)
2	Tx	O	RS232 transmit.
3	GND	GND	Ground.
4	Rx	I	RS232 receive.
5	NC	-	Not connected.

Default Current Setting

Default motor current setting of iST-23xx is 4.8A peak and it reduces to 50% automatically 400ms after the last pulse.

DIP Switch Settings

Micro Step Resolution (S1-S4)

Micro step resolution of the iST-23xx can be configured via DIP switch S1-S4 or Leadshine's tuning software ProTuner. When all S1-S4 are at "ON" positions, the drive will take the micro step resolution setting set by the software (4000 by default). In this case, a user can re-configure the resolution to any value between 200 and 512,000 (increased by 1) through software. If any bit of S1-S4 is at "OFF" position, the integrated drive board will take micro step resolution setting determined by bit positions of S1-S4. Use the following table for their resolution settings via the DIP switch.

Micro Step Resolution

Steps/Revolution	S1	S2	S3	S4
Software Configured(Default 400)	On	On	On	On
800	Off	On	On	On
1600	On	Off	On	On
3200	Off	Off	On	On
6400	On	On	Off	On
12800	Off	On	Off	On
25600	On	Off	Off	On
51200	Off	Off	Off	On
1000	On	On	On	Off
2000	Off	On	On	Off
4000	On	Off	On	Off
5000	Off	Off	On	Off
8000	On	On	Off	Off
10000	Off	On	Off	Off
20000	On	Off	Off	Off
40000	Off	Off	Off	Off

Motor Shaft Direction (S5)

DIP switch S5 is used for changing motor shaft rotation direction. Changing position from "ON" to "OFF", or "OFF" to "ON" will reverse rotation direction of the iST-23xx.

Self-Test (S6)

By default, DIP switch S6 is OFF (Normal Mode) and the iST-23xx responds to any pulse input. If it is turned ON, the iST-23xx goes into self-test mode. In self-test mode, the motor shaft rotates 1 revolutions CW and then 1 revolutions CCW. The self-motion repeats until S6 is turned OFF (the motor shaft will stop immediately). Note that you are unable to communicate with the iST-23xx via the RS232 port when it is in self-test mode.

Fine Tuning

Leadshine already loads default current-loop parameters for the iST-23xx. Those default parameter values have been optimized. They should be good enough for most industrial applications, and there is no need to tune them. However, if you want to fine tune the iST-23xx for best performance for your applications, Leadshine also offers tuning software, ProTuner, which allows you to adjust those current-loop parameters.

Typical Connections

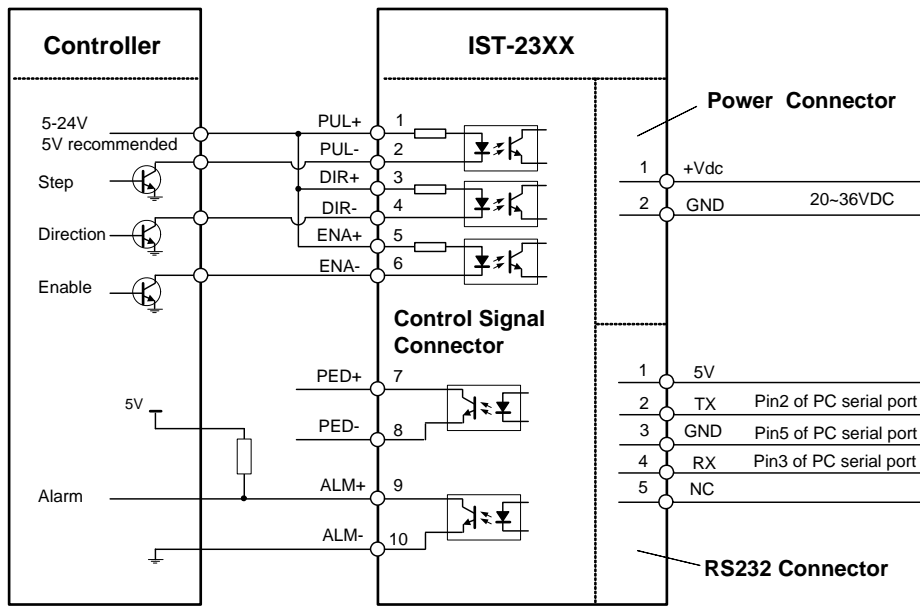

Connect IST-23XX to controller of sinking output

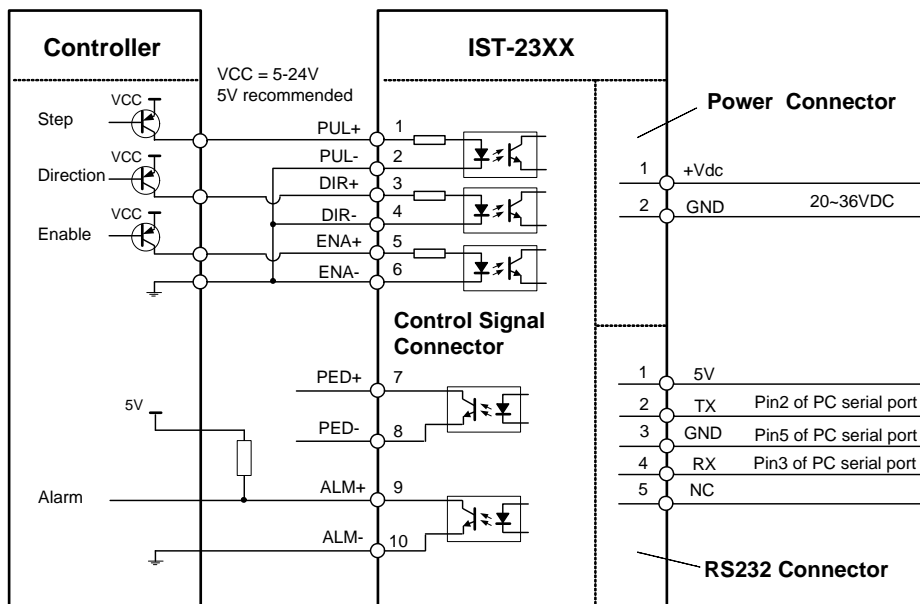

Connect IST-23XX to controller of sourcing output

Typical Connections (Continued)

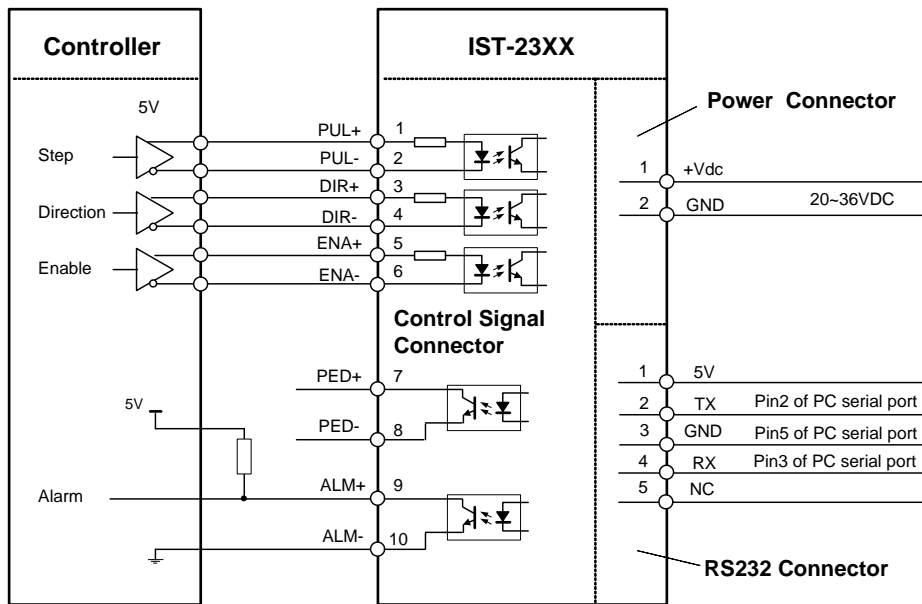

Connect IST-23XX to controller of differential output

RS232 Communication Cable Connections

Note1: The RS232 communication port is not isolated. Please use an isolated power supply for the iST-23xx when the PC's serial port is not isolated.

Note2: Do not plug or unplug the connector when power is on.

