

**INTRODUCTION**

The **RHT-P10** and **RHT-XS** transmitter series incorporate the best high accuracy and great stability relative humidity and temperature sensors. They convert the measured values into linear 4 to 20 mA signals and optional 0 to 10Vdc output can also be offered under request. The microprocessor based circuit enables full configuration of output range when used with the **TxConfig** PC interface and the Windows® based software.

**RHT-P10** model is aimed at humidity and temperature monitoring in pressurized or vacuum systems. Sensor probe in Stainless Steel can be thread mounted in the supplied flange or directly to the system wall or pipe.

**RHT-XS** is aimed at humidity and temperature monitoring in non-pressurized systems that require a remote sensor.



**FEATURES AND SPECIFICATIONS**

**Humidity Transmitter**

- Output resolution: 0.022 mA (4-20 mA) or 0.015 V (0-10 V)
- Accuracy: 3 % (refer to diagram)
- Range: Programmable anywhere from 0 to 100 %RH or -100 and 103 °C for dew point
- Response time: 8 seconds @ 25 °C (in fairly still air)

**Temperature Transmitter**

- Output resolution: 0.006 mA (4-20 mA) or 0.003 V (0-10 V)
- Accuracy: 0.5 °C (refer to diagram)
- Range: programmable between -40 and 120 °C
- Response time: up 30 seconds (in fairly still air)

**General Features**

- Output: - model 4-20 mA: 4-20 mA current, two-wire type  
- model 0-10Vdc: 0-10Vdc voltage
- Power: - model 4-20 mA: 12 Vdc to 30 Vdc  
- model 0-10 Vdc: 18Vdc to 30 Vdc
- Isolation between outputs: - Model 4-20 mA: isolated.  
- Model 0-10Vdc: non-isolated.

- Output load (RL):  
- model 4-20 mA: RL (max. em Ohms) = (Vdc - 12) / 0.02  
- model 0-10 Vdc: Minimum 10 kohms
- Configurable output range.
- Protection: - electronic module: IP65  
- sensor module: IP40
- Internal protection against reversed voltage wire polarity.
- Operating limits:  
- electronic module: -10 to +65 °C, 0 to 95 % RH  
- sensor module: -10 to +65 °C, 0 to 100 % RH  
- maximum gauge pressure (P10 sensor module): 10 bar (145 PSI)
- Cable input: Compress fitting PG7
- Cable length: 1.5 m
- Electronic module case: Polycarbonate

**P10 Sensor module**

- process connection : External thread ½" NPT, Stainless Steel 304
- sintered brass probe cover

**Measuring Accuracy and Sensor Operational Limits**

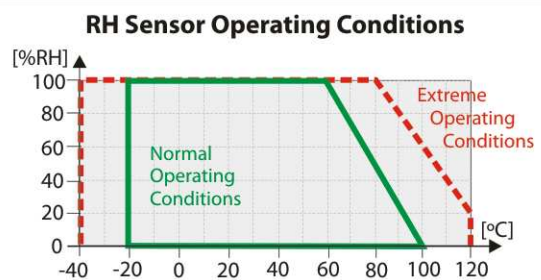
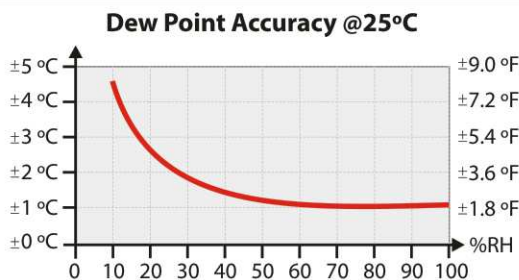
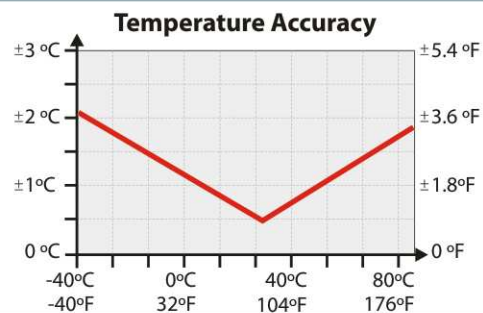
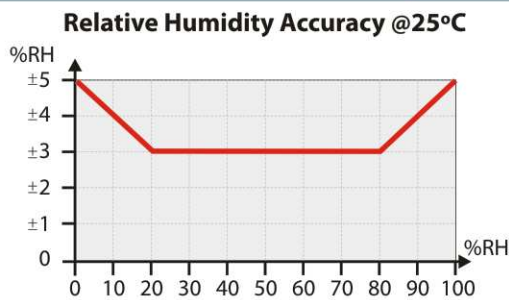

The RH sensor used in the equipment may be damaged or descalibrated when exposed to contaminated atmospheres or chemical agents. Hydrochloric, nitrous or sulphuric acid or ammonia in high concentrations may damage the sensor. Acetone, ethanol and propylene glycol may cause reversible measuring errors.

TEMPERATURE AND RELATIVE HUMIDITY TRANSMITTERS C

CONFIGURATION

RHT-WM and RHT-DM configuration is performed by using the TxConfig software and interface which is connected to the PC. With the configuration one can set the transmitted output range, correct measuring deviations (zero correction) and choose sensor failure conditions (upscale or downscale). Sensor internal information as serial number, product version and model can be also be digitally presented in the programming software menu. The factory default settings are:

- Humidity measuring range: 0 to 100 %;
- Temperature measuring range: 0 to 100 °C;
- Upscale signal outputs when sensor break or failure.

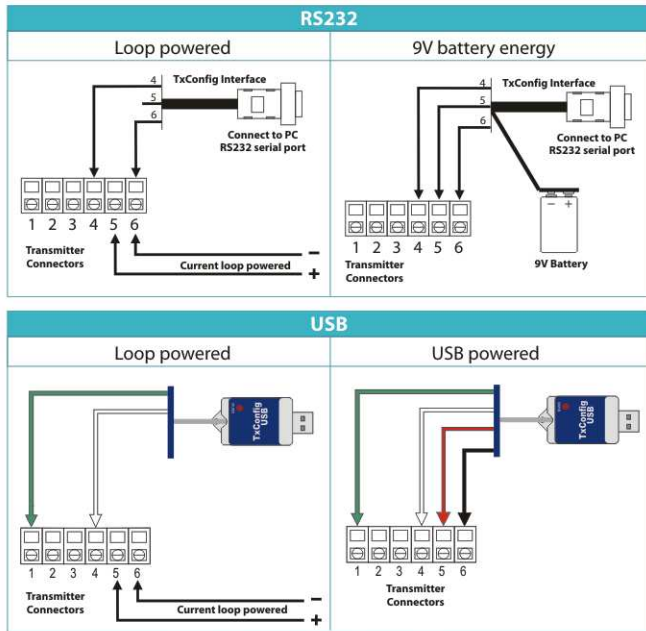

TxConfig Interface Connections

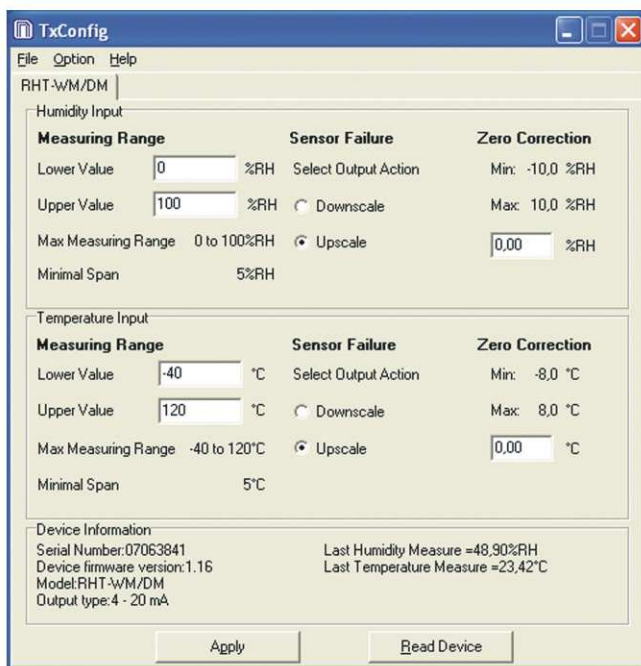

TxConfig software main prompt

INSTALLATION

RHT-P10 model

The electronic module contains two holes for mounting purposes, as seen in the below figure.

The sensor module is mounted by means of a metal flange, shown below.

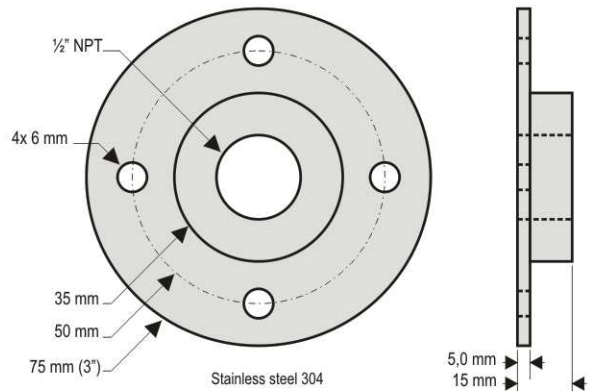
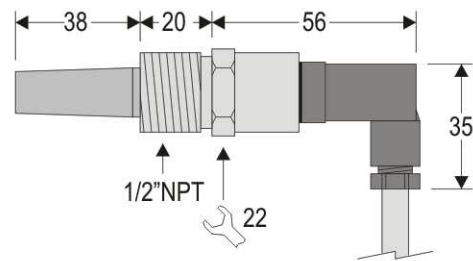
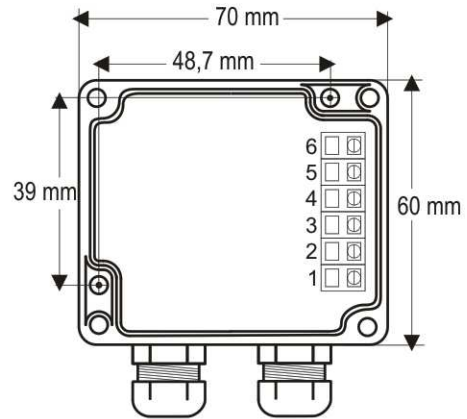

RHT-XS model

The electronic module is mounted in the same way as in the model RHT-P10.

The RHT-XS sensor module may be mounted to application's convenience (no specific requirements) or simply left in the ambient.

