

USER MANUAL

KTA-397 SMS Controller

Manual version 1.0

Jan 2026 Ocean Controls

Record of revisions

Revision 1.0	Initial Release
--------------	-----------------

1. Introduction

The KTA-397 is a versatile SMS-based monitoring and control device that allows users to manage multiple digital and analogue signals through its internal I/Os.

Users can fully customize alarm and control messages, which are sent to up to 10 preconfigured phone numbers once specific alarm conditions are met. The unit also accepts SMS commands from up to 10 authorized numbers to trigger its digital and analogue outputs.

This manual provides detailed technical specifications and operational instructions. It will be updated periodically as new features are released. Please visit www.oceancontrols.com.au to ensure you have the latest firmware and documentation.

If you have specific requirements or feature requests, feel free to contact us at info@oceancontrols.com.au.

1.1 Features

- Up to 10 user-defined controls (alarm) and actions
- Up to 10 receiver phone numbers
- Up to 10 control phone numbers
- Support custom control and alarm SMS messages
- 2 x Analogue inputs (programmable between 0-20mA, 4-20mA, 0-5V, 0-10V)
- 2 x Analogue outputs (programmable between 0-20mA, 4-20mA, 0-5V, 0-10V)
- 2 x Isolated digital inputs (3VDC to 30VDC)
- 2 x Relay outputs (3A @ 250VAC)
- 2 x 300mA Open Collector Outputs
- 9-36 VDC Powered
- DIN rail mountable
- Micro SIM card required

2. Connection Pin Assignments and LEDs Indication

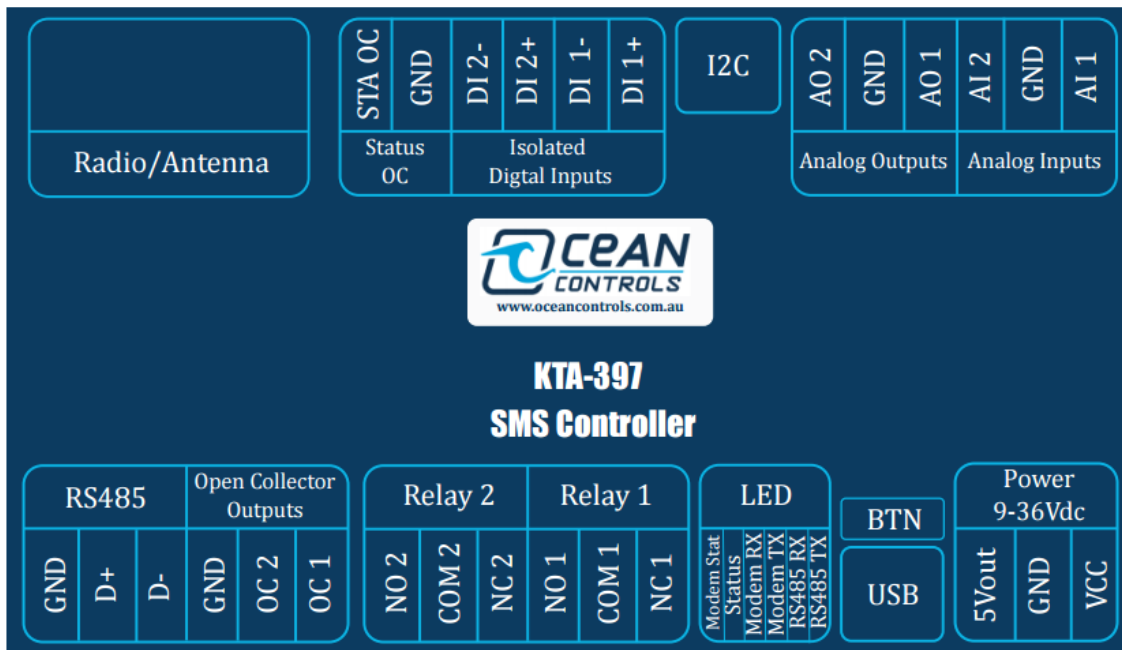

2.1 Power Connections

PIN	Details
V+	9-36VDC Power. External power required for analogue I/Os
GND	Common Ground
5Vout	5V DC Output for external signals

2.2 USB and Configuration Button

PIN	Details
USB-C	Used for communication and firmware update
BTN	Configuration Button <ul style="list-style-type: none"> Push and hold for 3 seconds: Start internal configuration WiFi Push and hold for 5 seconds: LTE Modem - USB Passthrough Push and hold for 10 seconds: Factory Reset

2.3 Digital Outputs

PIN	Details
NC 1	Relay 1 Normally Closed Contact (3A 240VAC/30VDC)
COM 1	Relay 1 Common Contact (3A 240VAC/30VDC)
NO 1	Relay 1 Normally Open Contact (3A 240VAC/30VDC)
NC 2	Relay 2 Normally Closed Contact (3A 240VAC/30VDC)
COM 2	Relay 2 Common Contact (3A 240VAC/30VDC)
NO 2	Relay 2 Normally Open Contact (3A 240VAC/30VDC)

OC 1	Open Collector Digital Output 1 (300mA 30VDC)
OC 2	Open Collector Digital Output 2 (300mA 30VDC)

2.4 Digital Inputs

PIN	Details
DI 1+	Positive side of optically isolated digital input 1 (5 to 30VDC)
DI 1-	Negative side of optically isolated digital input 1 (5 to 30VDC)
DI 2+	Positive side of optically isolated digital input 2 (5 to 30VDC)
DI 2-	Negative side of optically isolated digital input 2 (5 to 30VDC)

2.5 Analogue Inputs

PIN	Details
AO 1	Analogue Output 1 (selectable 0-20mA, 4-20mA, 0-5V or 0-10V)
AO 2	Analogue Output 2 0-20mA, 4-20mA, 0-5V or 0-10V
SW1 (Internal)	Toggle Voltage or Current mode
SW2 (Internal)	Toggle Voltage or Current mode

2.6 Analogue Outputs

PIN	Details
AI 1	Analogue Input 1 (0-20mA, 4-20mA, 0-5V or 0-10V)
AI 2	Analogue Input 2 (0-20mA, 4-20mA, 0-5V or 0-10V)
SW3 (Internal)	Toggle Voltage or Current mode
SW4 (Internal)	Toggle Voltage or Current mode

2.7 LEDs Indicators

PIN	Details
MODEM STATUS	Indicate network status of the module <ul style="list-style-type: none"> • Flicker slowly (200ms ON, 1800ms OFF): network searching • Flicker slowly (1800ms ON, 200ms OFF): idle • Flicker quickly (125ms ON, 125ms OFF): data transfer is ongoing
STATUS	Solid: Device running normally Blinking: Device configuration WiFi on
RS485 TX (RED)	Indicate RS485 message Sent from Device
RS485 RX (GREEN)	Indicate RS485 message Received by Device
MODEM TX (RED)	Indicate SMS Message sent from Device
MODEM RX (GREEN)	Indicate SMS Message received by Device

3. Analogue I/Os switching and Calibration

The KTA-396x's analogue I/Os can operate in voltage or current mode. To switch between these 2 mode, please use the onboard slide switches to the corresponding positions: "Up = Voltage mode" and "Down = Current mode".

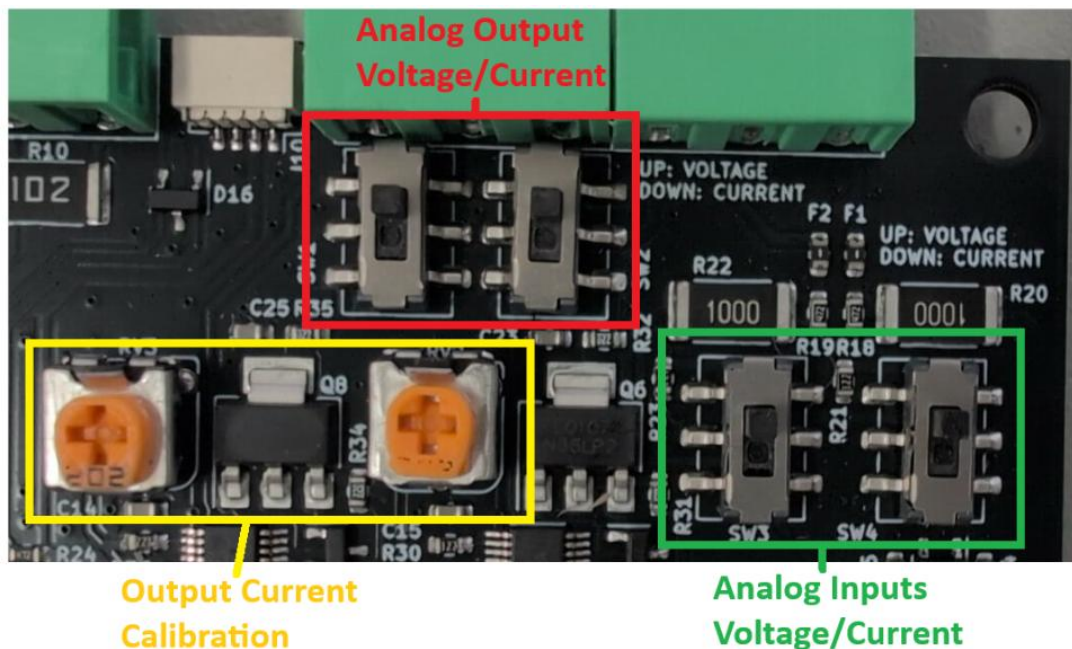

Please note that switching the analogue mode will reset the current reading to 0. Therefore, make sure you currently have no active input on the other node while switching the I/Os.

With Analog Outputs in current mode, user can adjust the device's hardware calibration using the yellow trim pots. By default, these are set to output maximum 20mA.

4. Specifications

4.1 Electrical Specifications

Parameters	Min	Typical	Max	Unit
Voltage supply	9	--	36	V DC
Power required		1.2		W
Digital Inputs	5		30	V DC
Relay Outputs	3A at 240VAC or 30VDC			
Open Collector Outputs	300mA at 30VDC			
Analogue Inputs	Maximum 0-10V or 0-20mA			
Analogue Outputs	Maximum 0-10V or 0-20mA			
SIM Card	Micro SIM			

4.2 Environment

Parameters	Min	Typical	Max	Unit
Operating Temperature	-20	25	80	°C

4.3 Physical Dimensions

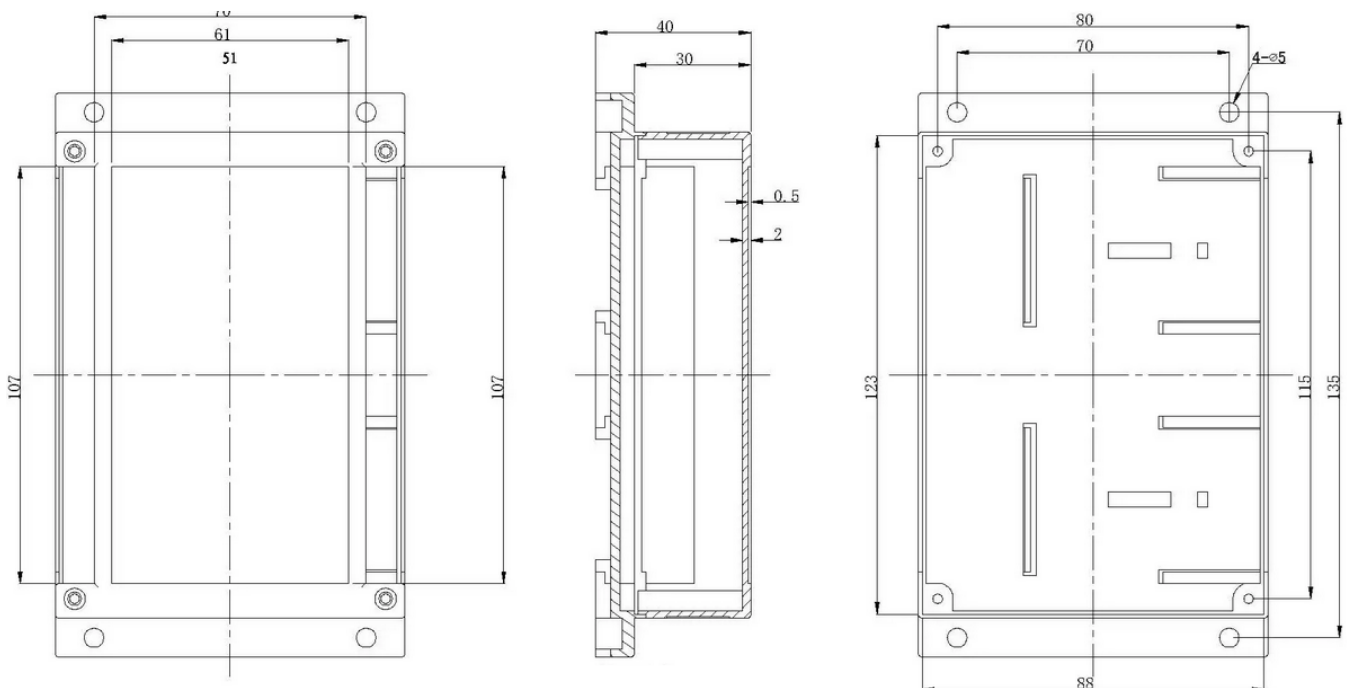

5. Quick Start

Step 1: Attach Antenna – Screw the provided LTE antenna onto the KTA-397’s SMA connector.

Step 2: Insert SIM – Insert a micro-SIM card into the designated slot.

Step 3: Power Up – Connect the power supply to the device (9-36VDC).

Step 4: Network Sync – Wait roughly 5 minutes for the LTE modem to link with your service provider. Connection is confirmed once the MODEM Status blink slowly (see LED behavior above).

Step 5: WiFi Setup – Using a smartphone or laptop, follow the instructions in Section 6 to enable the internal WiFi network.

Step 6: Configuration – Program the device settings as required for your application.

6. Device Configurations

6.1 Access Configuration Interface

To access the configuration settings, you first need to enable the KTA-397’s internal WiFi network. Please follow these steps:

- **Activating the WiFi Network:** Press and hold the Configuration Button (BTN) for 3 seconds. Release the button once you see two green LEDs.
- **Confirm Status:** The blue STATUS LED will begin to blink slowly. This indicates the WiFi is now active. (Note: The WiFi network will automatically turn off after 30 minutes)
- **Connect Your Device:** On your phone or computer, scan for available WiFi networks and select KTA3970_XXXX. The default password is “password”.
- **Access the Interface:** If you are using a mobile phone (recommended), the configuration page should launch automatically. If it doesn’t, or if you are using a computer, open your web browser and navigate to the device’s address: kta3970.local

The configuration pages are shown in more details below.

6.2 Monitor Page

This page shows the real-time status of the I/Os and the details of the LTE modem network provider. Data is updated every 2 seconds.

Hardware I/Os Status

Digital Inputs

Digital Input 1 Status: OFF

Digital Input 2 Status: OFF

Analog Inputs

Analog Input 1 Type: VOLTAGE

Analog Input 1 Real Input: 0

Analog Input 1 Ratio Input: 0 %

Analog Input 2 Type: VOLTAGE

Analog Input 2 Real Input: 0

Analog Input 2 Ratio Input: 0 %

Digital Outputs

Relay 1 Status: OFF

Relay 2 Status: OFF

Open Collector 1 Status: OFF

Open Collector 2 Status: OFF

Modem Network Status

Network Registration: **Registered**

Network Operator: **Catch**

Network Technology: **FDD LTE**

Network Band: **LTE BAND 3**

Network SMS Center Number: **+61411990001**

Network Signal Strength: **25**

6.3 Hardware Configuration Page

This page allows you to configure the device’s hardware I/O settings. Each section has its own corresponding Set/Save button.

For **Digital Inputs**, this section allows you to set each Channel to be ACTIVE with LOW or HIGH signal.

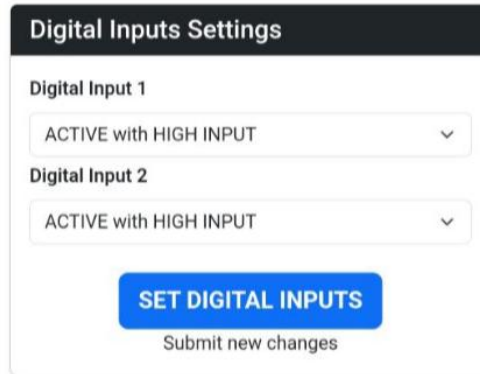

The screenshot shows the 'Digital Inputs Settings' form. It contains two dropdown menus for 'Digital Input 1' and 'Digital Input 2', both currently set to 'ACTIVE with HIGH INPUT'. Below the dropdowns is a blue button labeled 'SET DIGITAL INPUTS' with the text 'Submit new changes' underneath it.

For the **Analogue Inputs and Analogue Outputs**, this section allows you to select the voltage or current type in each mode.

- **Analog Input Real Minimum Value:** Minimum Engineering Value that unit will display and use as alarm condition.
- **Analog Input Real Maximum Value:** Maximum Engineering Value that unit will display and use as alarm condition.

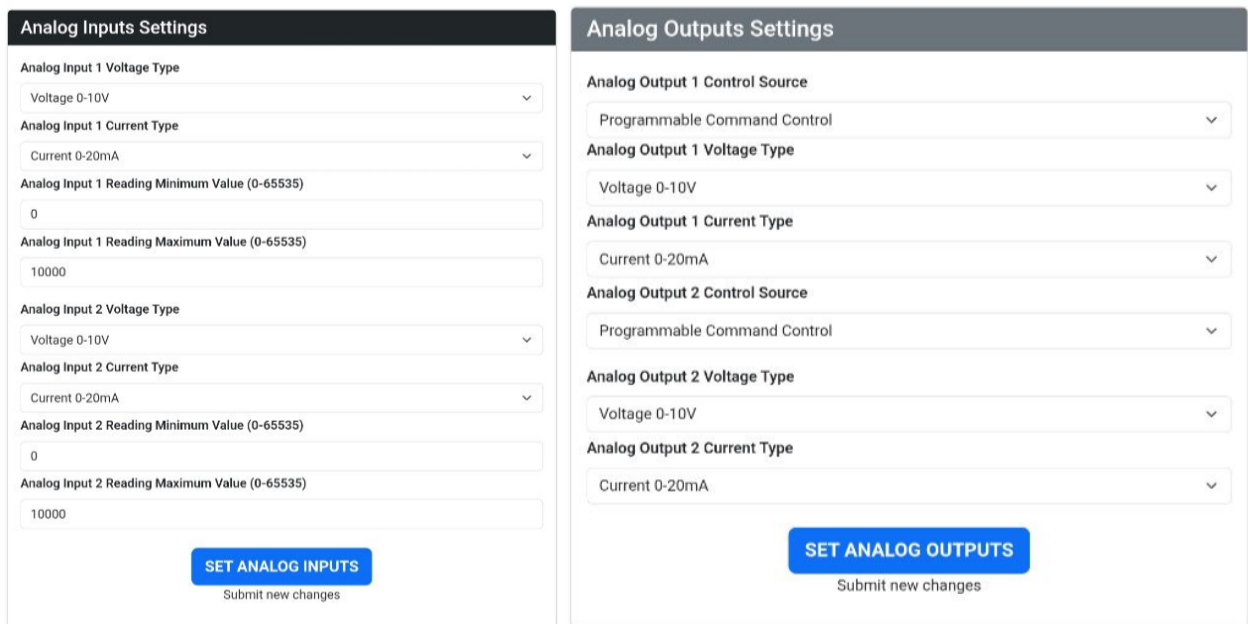

The image shows two side-by-side screenshots of configuration forms. The left form is 'Analog Inputs Settings' and the right is 'Analog Outputs Settings'.
 The 'Analog Inputs Settings' form includes:
 - Analog Input 1 Voltage Type: Voltage 0-10V
 - Analog Input 1 Current Type: Current 0-20mA
 - Analog Input 1 Reading Minimum Value (0-65535): 0
 - Analog Input 1 Reading Maximum Value (0-65535): 10000
 - Analog Input 2 Voltage Type: Voltage 0-10V
 - Analog Input 2 Current Type: Current 0-20mA
 - Analog Input 2 Reading Minimum Value (0-65535): 0
 - Analog Input 2 Reading Maximum Value (0-65535): 10000
 A blue button 'SET ANALOG INPUTS' with 'Submit new changes' is at the bottom.
 The 'Analog Outputs Settings' form includes:
 - Analog Output 1 Control Source: Programmable Command Control
 - Analog Output 1 Voltage Type: Voltage 0-10V
 - Analog Output 1 Current Type: Current 0-20mA
 - Analog Output 2 Control Source: Programmable Command Control
 - Analog Output 2 Voltage Type: Voltage 0-10V
 - Analog Output 2 Current Type: Current 0-20mA
 A blue button 'SET ANALOG OUTPUTS' with 'Submit new changes' is at the bottom.

By default, the values are set to 0-10000 range for both 0-10V and 0-20mA.

6.4 Communication Configuration Page

This page allows you to access the 10 “Controls – Actions”, modify the SMS Center Number and edit the phone books for receiving and controlling.

a. Control Actions Section



This section lists the active (Green) Actions and inactive (Blue) action. You can select each action which will take you to its Programming Page.

b. Modem Settings

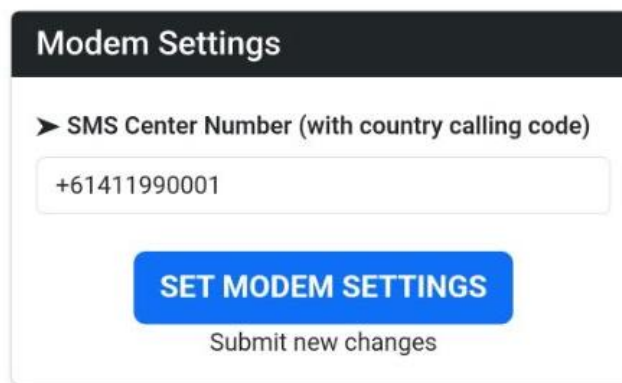

You can make changes to the SMS Center Number here if it was not detected correctly. For Australia, here are the SMS center number from popular service providers:

Network Provider	SMS Center Number
Telstra	+61418706700
Optus	+61411990001
Vodafone	+61415011501
ALDI Mobile	+61418706275
LycaMobile	+61469000111

Please note the phone number must start with the international country code.

c. Phone Book

This section allows you to manage the Receiving and Controlling phone lists. Each list supports a maximum of 10 phone numbers.

- **Receiving Numbers:** When an alarm is triggered and an alarm SMS is set, the device will send this programmed SMS alert to every number on this list.
- **Controlling Numbers:** Any SMS command sent to the device to trigger an action must originate from one of these numbers to be accepted.

All phone numbers must start with the country calling code.

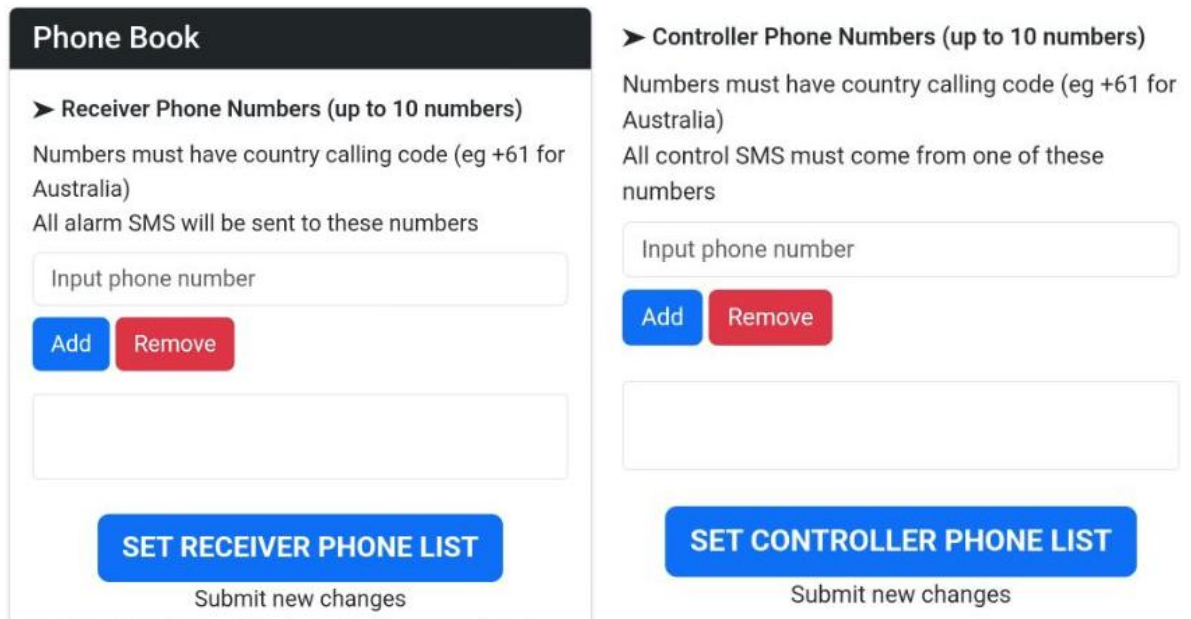

The screenshot displays the 'Phone Book' configuration interface, divided into two main sections: 'Receiver Phone Numbers' and 'Controller Phone Numbers'. Both sections allow for up to 10 numbers and require a country calling code (e.g., +61 for Australia). Each section includes an input field for a phone number, 'Add' and 'Remove' buttons, and a large blue button to 'SET' the list, with a 'Submit new changes' label below it.

Phone Book

► **Receiver Phone Numbers (up to 10 numbers)**
Numbers must have country calling code (eg +61 for Australia)
All alarm SMS will be sent to these numbers

Input phone number

Add Remove

SET RECEIVER PHONE LIST
Submit new changes

► **Controller Phone Numbers (up to 10 numbers)**
Numbers must have country calling code (eg +61 for Australia)
All control SMS must come from one of these numbers

Input phone number

Add Remove

SET CONTROLLER PHONE LIST
Submit new changes

6.5 Control – Action Page

This page allows you to set a Control (Trigger Alarm) and up to 3 corresponding Actions for that trigger.

a. Control condition

Currently supported conditions are:

- Digital Input 1 Status (Active or Inactive)
- Digital Input 2 Status (Active or Inactive)
- Analogue Input 1 value (equal, not equal, larger, lower, larger equal, lower equal)
- Analogue Input 2 value (equal, not equal, larger, lower, larger equal, lower equal)
- SMS Message Received (only from control number list)

For **Analogue Inputs**, please use the “Real Value range” setup in the Hardware Configuration above.

You can also specify a **Duration/Delay** time in seconds. This means the alarm will not trigger until the duration has elapsed. The maximum value is 65535 seconds (~1092 minutes or ~18 hours). The alarm will trigger instantly if the Duration is set to 0 (default).

Trigger Condition

▶ Type

Internal Analog Input 1
▼

▶ Condition

Larger Than
▼

▶ Setpoint

100
↻

Use Real Value Range

▶ Duration (seconds)

0

b. Actions (Action 1, Action 2 and Action 3)

These actions will trigger when the condition above is met. Action 1 will have a few more options than Action 2 and 3. Action 2 and 3 can also be set to unused.

Currently supported actions:

- Relay 1 (Active or Inactive)
- Relay 2 (Active or Inactive)
- Open Collector 1 (Active or Inactive)
- Open Collector 2 (Active or Inactive)
- Analogue Output 1
- Analogue Output 2
- Send SMS (only available with Action 1)

For **Analogue Outputs**, please use the “Actual Value range”:

- For Voltage Output: range 0-1000
- For Current Output: range 0-2000

For example, if Analogue Output 1 is set to Voltage Mode 0-10V and the setpoint is 450, it will output 4.5V when the control action is triggered.

You can also specify a **Duration/Delay** time in seconds. This means the action will only be activated for this period and will revert to an opposite state (or output 0) after the timing has elapsed. The maximum value is 65535 seconds (~1092 minutes or ~18 hours).

The action will be activated indefinitely if Duration is set to “0”.

Action 1

Type
Send SMS

Control Action/Value
Command Received
Maximum 165 characters

Duration (seconds)
0

Action 2

Type
Internal Analog Output 1

Control Action/Value
450
Use Actual Value Range

Duration (seconds)
0

7. Default Parameters/Factory Reset

As of current firmware, the factory reset function will reset the device to these parameters:

- **RS-485 Modbus parameters:**
 - Modbus Address: 1
 - Modbus Baudrate: 115200
 - Modbus Config: 8 Data Bits, No Parity, 1 Stop Bit
- **Digital inputs Active State:** High
- **Digital outputs control sources:** Controls Action
- **Analog inputs range:** 0-10,000
- **Analog inputs hysteresis:** 100
- **Analog outputs range:** 0-1,000
- **Analog outputs control sources:** Control Action