



## SPECIFICATIONS

Item No.: SCA141A

Description: Relay Output Type Tilt Switch

### **Production implementation standard reference**

- Enterprise quality system standards: ISO9001: 2008 standard (certification number: 128101)
- Tilt sensor production standards: GB / T 191 SJ 20873-2003 inclinometer general specification of Level
- The Academy of metrology and quality inspection Calibrated in accordance to: JJF1119-2004 Electronic Level calibration Specification
- Gyro accelerometer test standard: QJ 2318-92 Gyro accelerometer test methods
- Software development reference standard: GJB 2786A-2009 military software development General requirements
- Product environmental testing standards: GJB150
- Electromagnetic anti-interference test standards: GB / T 17626
- Ver.:05
- Date:2014.4.25

# SCA141A- Relay Output Type Tilt Switch



## General Description

SCA141A is a digital type dual-axis tilt switch developed by RION company who integrated Finland control core unit , and based on level security alarm and platform leveling detection related industries application , built-in relay output circuit . Users can set alarm angle value by themselves, it will output a no contact relay signals (drive current 1A)when exceeds the safety angle value, Open the electronic valve to control the corresponding hydraulic leg leveling .This product with design precision, again to compensate the temperature and linearity, integrated short-circuit, high-voltage transient, polarity and surge etc. full protection functions, suitable for a variety of harsh industrial environments operating. Using the industrial grade MCU, three-anti PCB, import cable, wide temperature metal enclosure and other measures etc. to improve the industry level on products reliability and stability.

## Features:

- Dual-axis tilt switch
- Accuracy: please refer to the technical data
- RS232 series output
- Switch output (high-low level)
- Resolution : 0.01°
- Wide temperature working: -40~+85°C
- IP67 protection class
- Highly anti-vibration performance>2000g
- Direct lead cable interface
- Customer can set alarm angle value by himself
- With Setting 0° function
- Positive/negative direction output is optional
- DC 9~36V wide voltage input

## Application:

- Engineering mechanical vehicles
- Rail-mobile monitoring
- Radar detection of vehicle platform
- Underground drill posture navigation
- Based on the angle direction measurement
- Shield pipe jacking application
- Ship's navigation posture measurement
- Geological equipment inclined monitoring
- Various engineering mechanical measurement of dip angle
- The intelligent excavator / crane / cranes / pile driver / drill machine / special vehicles / mine car / track car / fire truck / aerial vehicles / bridge machine



## Ordering information:

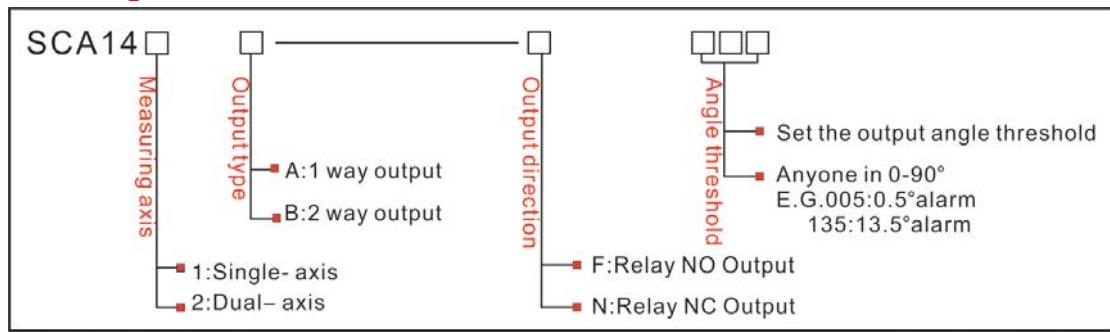

E.g: SCA141A-F005 : Single-axis/1 way/ Relay normal open output /0.5° alarm

Note: 1) Different models with different color line function definition, please refer to ordering Information description before ordering ;

2) The factory default alarm threshold:  $\pm 2^\circ$  (also can be customized according to customer requests), refer to the ordering information;

## Technical Data :

Parameters	Conditions	SCA141A-N015	UNIT
Measuring rang		$\pm 15$	$^\circ$
Measuring axis		X,Y	
Resolution		0.01	$^\circ$
Absolute accuracy		0.05	$^\circ$
Long term stability		0.05	
Zero temperature coefficient		-40~85° $\pm 0.006$	$^\circ/^\circ\text{C}$
Sensitivity temperature coefficient		-40~85° $\leq 100$	ppm/ $^\circ\text{C}$
Power on time		0.1	S
Response time		0.2	s
EMC	According to EN61000 and GBT17626		
MTBF	$\geq 50000$ hours/times		
Insulation Resistance	$\geq 100\text{M}$		
Shockproof	100g@11ms、3Times/Axis(half sinusoid)		
Anti-vibration	10grms、10~1000Hz		
Protection glass	IP67		
Cables	Standard 1M length、wearproof、grease proofing、wide temperature、Shielded cables 4*0.4mm <sup>2</sup>		
Weight	120g(without cable)		

## Electronic Characteristics

Parameters	Conditions	Min	Standard	Max	Unit
Power supply	Standard	9	12、 24	36	V
Alarm output current				1000	mA
Working current	No-load		40		mA
Working temperature		-40		+85	°C
Store temperature		-55		+125	°C

## Key words:

**Resolution:** Refers to the sensor in measuring range to detect and identify the smallest changed value.

**Absolute accuracy:** Refers to in the normal temperature circumstances, the sensor absolute linearity, repeatability, hysteresis, zero deviation, and transverse error comprehensive error.

**Long term stability :** Refers to the sensors in normal temperature conditions, the deviation between the maximum and minimum values after a year's long time work.

**Response time:** Refers to the sensor in an angle change, the sensor output value reached the standard time required.

## Mechanical Parameters

- Connectors: 1m lead cable (Length can be customized)
- Protection glass: IP67
- Enclosure material : Aluminum Oxide
- Installation : 4\*M6 screws



## Working Principle

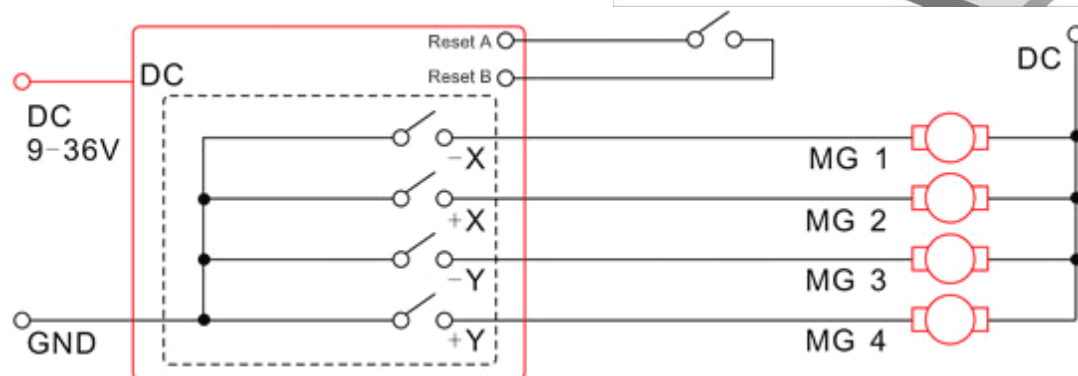

Above figure is the working principle diagram of the dual-axis with 4 ways output switch, the output signal is the relay switch signal, each output terminal corresponding to a switch inside the tilt switch (Inside dashed frame with representation), the one end of the switch in the figure are in the internal connected to GND. With COM Common terminal switch the internal switch is connected to the COM terminal unified, the customer can connect the COM terminal is connected to the power supply or ground according to the actual needs;

# SCA141A- Relay Output Type Tilt Switch

In this figure, when the inclination reaches the preset threshold of the positive X direction, MG1 starts, When the the inclination reaches x reverse direction preset threshold, MG2 start, MG3 MG4 and so on;

To set the relative angle, shorting cleared the A line and cleared the B line for 2 seconds .

## Dimension:

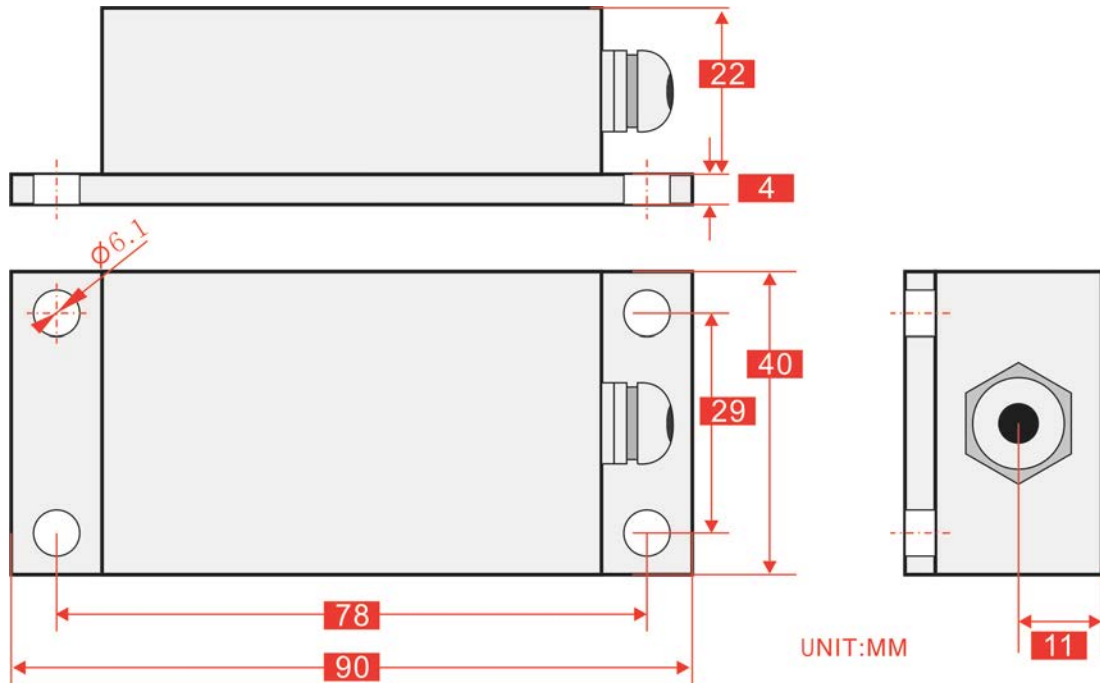

**SIZE:90mm×40mm×26**

## Production installation notes:

Please follow the correct way to install tilt sensor, incorrect installation can cause measurement errors, with particular attention to the "surface", "line": 1) The Sensor mounting surface and the measured surface must be fixed closely, smoothly, stability,if mounting surface uneven likely to cause the sensor to measure the angle error. See Figure Pic.AB

2) The sensor axis and the measured axis must be parallel ,the two axes do not produce the angle as much as possible. See Figure Pic.CD

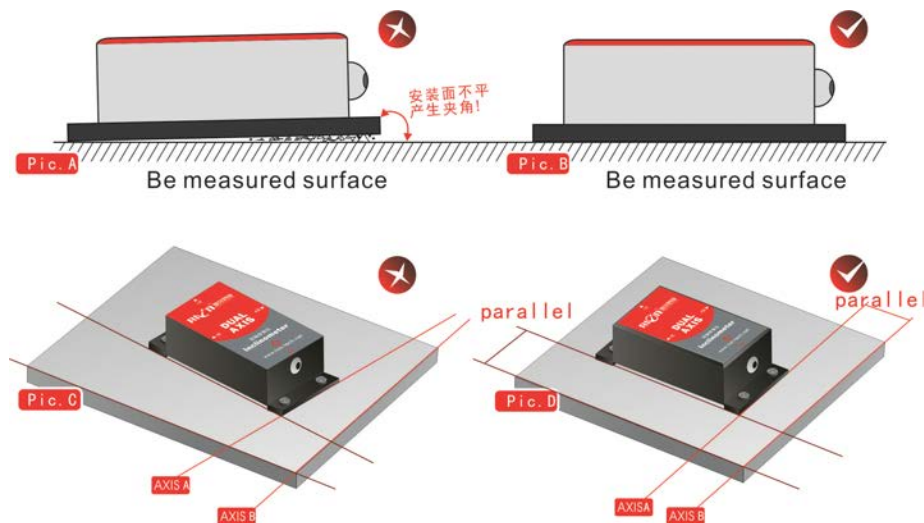



## Measuring Directions&Fix

The installation must guarantee the product bottom is parallel to measured face, and reduce the influence of dynamic and acceleration to the sensor. This product can be installed horizontally or mounted vertically (mounted vertically selection is only applicable to the single axis, and only can do relative measurement , if absolute measurement the level reference will occur error ), for installation please refer to the following scheme.

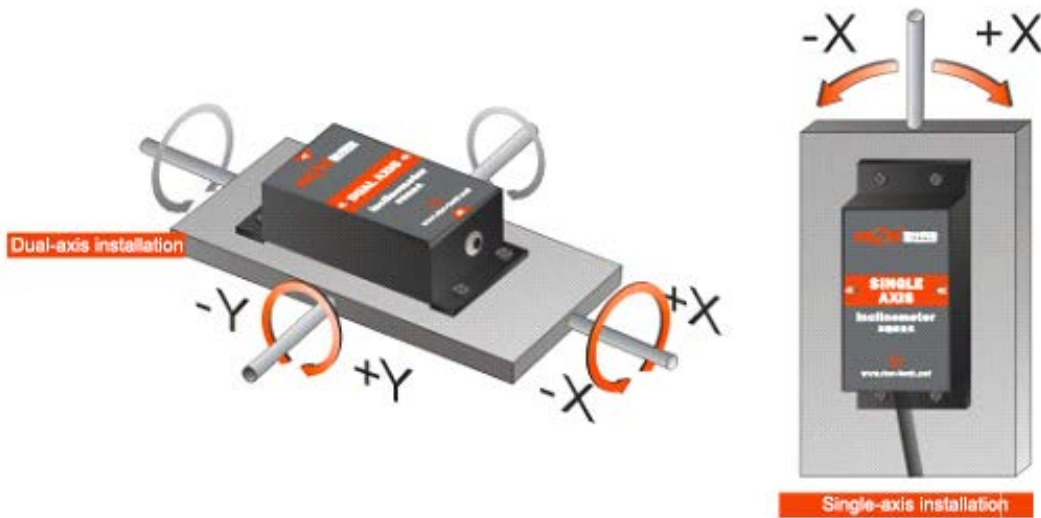

## Electrical Connection

Color definition	Single axis with 1 way output	Single axis with 2 ways output	Dual axis with 1 way output	Dual axis with 2 ways output
<b>Red</b>	Power positive	Power positive	Power positive	Power positive
<b>Black</b>	GND Zero clearing A	GND	GND Zero clearing A	GND Zero clearing A
<b>Green</b>	Zero clearing B	Zero clearing A /RXD	Zero clearing B	Zero clearing B
<b>Orange</b>	RXD	+X alarm	RXD	-Y alarm
<b>Purple</b>	TXD	+ X common terminal	TXD	+Y alarm
<b>Yellow</b>	X Axis normal close	- X Alarm	X Y Axis normal close	+X Alarm
<b>Blue</b>	X axis normal open	-X Common Terminal	X Y Axis normal open	-X Alarm
<b>Brown</b>	Common Terminal	Zero clearing B/TXD	Common Terminal	Common Terminal

### Note:

- 1) RXD and TXD two lines can be used to connect to the computer, through the software to set the alarm threshold. (-X, + X,-Y, + Y) can be set different threshold;
- 2) Connected to the computer to set the alarm value ,RXD and TXD connection please refer to the following figure:
- 3) If the line color no RXD and TXD function, alarm valve only allow factory Settings, the customer can

# SCA141A- Relay Output Type Tilt Switch

not change;

4) If you are using a laptop debugging you also need a RS232 to USB module, if the PC can be directly connected communication with the computer COM port.( If use converter must install conversion module driver can be use)

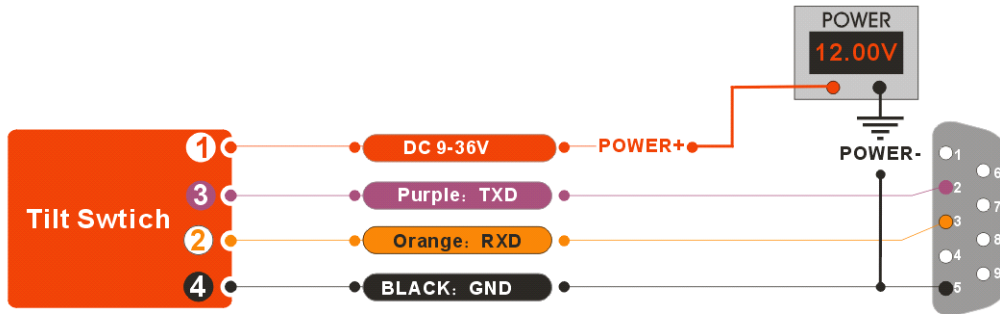

## RION Product debugging software

If you want to change the alarm thresholds, can communicate with computer and use the serial debugging assistant software to change .

Your can download the common public serial port debugging assistant software on line, Rion's products supporting debugging software can connect the inclinometer by itself on computer and display the angle , also can download the public serial port debugging software on line !

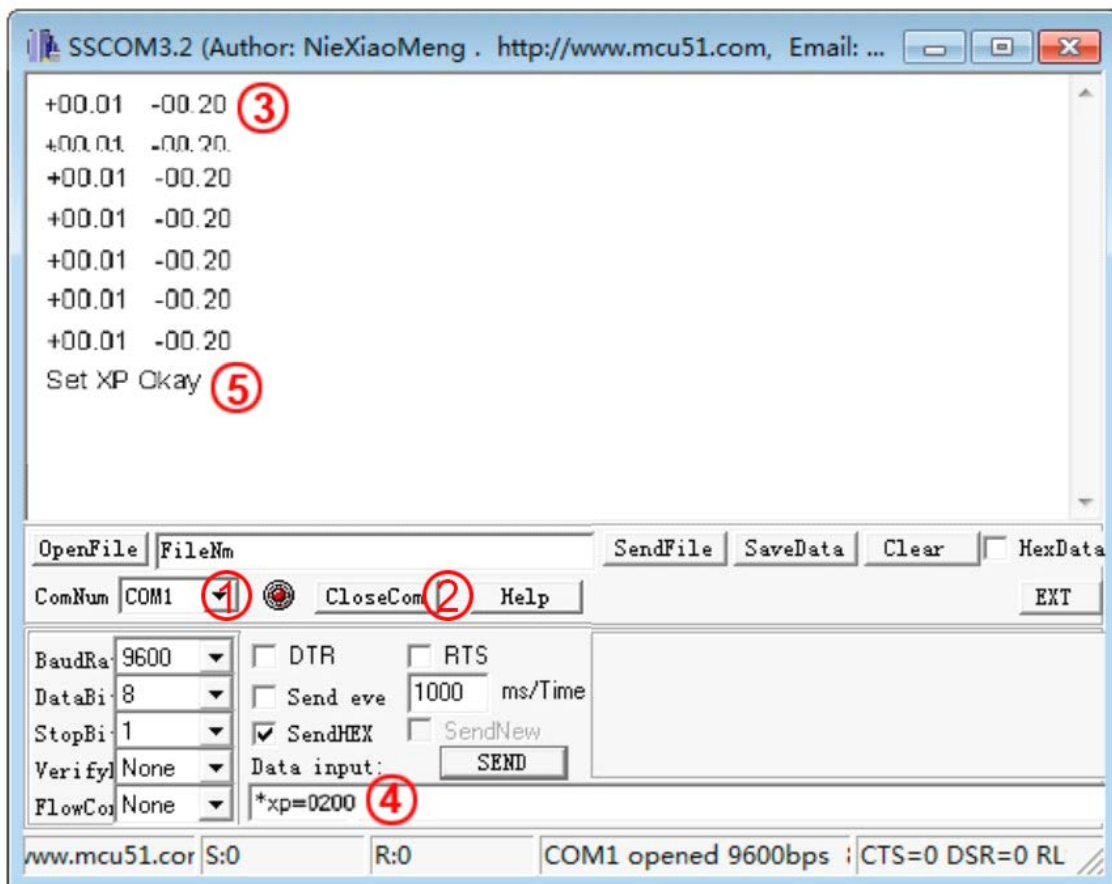

Debug process:

- 1) Open software;
- 2) Select the corresponding COM port, refer to 2".

- 3) Other settings are default setting , no need to set. "
- 4) Click to open the serial port button, refer to 2 "
- 5) This data will display in the return data area, refer to 3"
- 6) If you want to set the alarm threshold, please input setting alarm threshold command in input area, refer to 4" . ( For command please refer to the specification of communication protocol .)
- 7) When the return data area display " command +Okay" proved successful setting. Refer to 5"

## Common problem analysis of connection failure:

- A ) Check power: check positive & negative, whether it is DC?
- B ) Exchange RXD and TXD two data lines re-debugging;
- C ) COM occupancy, close other COM port testing device;
- D ) The black line no connection with the fifth pin of COM port.
- E ) If use RS232 converter, please check if the converter can work properly, whether the driver is installed;
- F ) Please use multimeter to measure the sensor current, if lower than 20mA or bigger than 60mA can judge the sensor was damaged.

## RION product communication protocol

一、 **DATA FRAME FORMAT:** ((8 bits date, 1 bit stop, No check, Default baud rate 9600)

### Angle output format (ASCII code)

A set of output data from a total of 18 bytes:

Byte1: X	Byte10: Y
Byte2: +/-	Byte11: +/-
Byte3: X	The tens column of axis angle value
Byte4: X	The single digit of axis angle value
Byte5: decimal point "."	Byte14: decimal point "."
Byte6: X	The decile of axis angle value
Byte7: X	The percentiles of axis angle value
Byte8: blank space (0x20)	Byte17: Enter (0x0D)
Byte9: blank space (0x20)	Byte18: Line feed (0x0A)

Format as following:

ITEAM	SIGNED	DATA	SPACE	SPACE	ITEAM	SIGNED	DATA	ENTER	NEWLINE
X	+/-	**.**	Blank space	Blank space	Y	+/-	**.**	Enter	Line feed

*E.g: the current X axis angle is +01.50deg, Y axis - 01.00 deg, then display X+01.50; Y-01.00*

Note: If the user set the relative zero when power on last time, then power on this time, the system will output: "relative angle measure!"

二: The relative setting command ( the following command case-sensitive )

Command	Description
&Z	The current position is relative ZERO, related data will be stored in EEPROM, and carry out relative angle output , after accepting command then output :“set relative zero” .
&R	The absolute angle output , after accepting command then output: “absolute zero”.
*xp=????	Setting positive half axis of X axis to be alarm point,“????” is angle value, optional value from “0001—1000”. The default is 0150。 After accepting command then output: “SetxP

OK!”



## SCA141A- Relay Output Type Tilt Switch

*xn=????	*xn=????— Setting negative half axis of X axis to be alarm point,“????” is angle value, optional value from “0001—1000”。 The default is 0150。 After accepting command then output: “SetxN OK!”
*yp=????	*yp=????—Setting positive half axis of Y axis to be alarm point,“????” is angle value, optional value from “0001—1000”。 The default is 0150。 After accepting command then output: “SetyP OK!”
*yn=????	*yn=????—Setting negative half axis of Y axis to be alarm point, “????” is angle value, optional value from “0001—1000”。 The default is 0150。 After accepting command then output: “SetyN OK!”

Short-circuit the green line and brown line for 2 seconds then open , to set the current angle to be relative ZERO, this function same as “&Z” command , the difference is after using this method to set the ZERO point successfully, there will be approximately 1 second alarm signal output, while “& Z” command without this indication.(Don't use the function please keep the green line disposed of properly , to avoid short-circuit with other lines .)



※More information please visit Rion's company website: [www.rion-tech.net](http://www.rion-tech.net)



**深圳市瑞芬科技有限公司**  
CHINA SHENZHEN RION TECHNOLOGY CO.,LTD.

✓ 倾角传感器    ✓ 倾角（调平）开关    ✓ 数显水平仪    ✓ 陀螺仪  
✓ 三维电子罗盘    ✓ 加速度计    ✓ 航姿参考系统    ✓ 寻北仪

T: 0755-29657137 / 29761269    F: 0755-29123494  
W: [www.rion-tech.net](http://www.rion-tech.net)    E: [sales@rion-tech.net](mailto:sales@rion-tech.net)  
A: 中国·深圳市宝安区82区华丰科技园五期3F

*Attitude Solution Provider*  
姿态方案解决专家！