

User manual WEIGHT METER SWI-94

- Input type: load cells
- Calibration using theoretical characteristic or real load

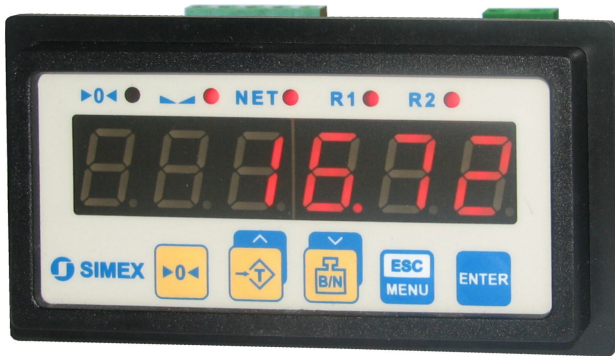

Read the user's manual carefully before starting to use the unit or software.
Producer reserves the right to implement changes without prior notice.

CONTENTS

1. BASIC REQUIREMENTS AND USER SAFETY.....	<u>3</u>
2. GENERAL CHARACTERISTICS.....	<u>4</u>
3. TECHNICAL DATA.....	<u>4</u>
4. DEVICE INSTALLATION.....	<u>6</u>
4.1. UNPACKING.....	<u>7</u>
4.2. ASSEMBLY.....	<u>7</u>
4.3. CONNECTION METHOD.....	<u>11</u>
4.4. MAINTENANCE.....	<u>20</u>
5. FRONT PANEL DESCRIPTION	<u>21</u>
6. PRINCIPLE OF OPERATION.....	<u>22</u>
6.1. MEASUREMENT MODE.....	<u>22</u>
6.2. DETECTION OF THE PEAK VALUES.....	<u>23</u>
6.3. CONTROL OF THE RELAY OUTPUTS.....	<u>24</u>
6.3.1. One threshold mode.....	<u>25</u>
6.3.2. Two thresholds mode.....	<u>26</u>
7. DEVICE PROGRAMMING.....	<u>27</u>
7.1. PROGRAMMING MENU.....	<u>27</u>
7.2. PARAMETERS EDITION.....	<u>28</u>
7.2.1. Numeric parameters (digit change mode).....	<u>28</u>
7.2.2. Numeric parameters (slide change mode).....	<u>28</u>
7.2.3. Switch parameters ("LIST" type).....	<u>29</u>
7.3. MENU DESCRIPTION.....	<u>29</u>
7.3.1. "rELAy1" menu.....	<u>29</u>
7.3.2. "bEEPER" menu.....	<u>32</u>
7.3.3. "CALibr" menu.....	<u>32</u>
7.3.4. "OutPUT" menu.....	<u>34</u>
7.3.5. "button" menu.....	<u>36</u>
7.3.6. "Pr inP" parameter.....	<u>37</u>
7.3.7. "HOLd" menu.....	<u>37</u>
7.3.8. "briGHt" parameter.....	<u>37</u>
7.3.9. "SECUR" menu.....	<u>38</u>
7.3.10. "rS-485" menu.....	<u>38</u>
7.3.11. "Edit t" parameter.....	<u>39</u>
7.3.12. "dEFS" parameter.....	<u>39</u>
7.3.13. "SErv" menu.....	<u>39</u>
7.4. MENU STRUCTURE.....	<u>40</u>
8. OUTPUT VALUE CALCULATION.....	<u>42</u>
9. SIGNALISATION OF ERRORS.....	<u>42</u>
10. THE MODBUS PROTOCOL HANDLING.....	<u>43</u>
10.1. LIST OF REGISTERS.....	<u>43</u>
10.2. TRANSMISSION ERRORS DESCRIPTION.....	<u>48</u>
10.3. EXAMPLES OF QUERY/ANSWER FRAMES.....	<u>48</u>
11. DEFAULT AND USER'S SETTINGS LIST.....	<u>51</u>

Explanation of symbols used in the manual:



- This symbol denotes especially important guidelines concerning the installation and operation of the device. Not complying with the guidelines denoted by this symbol may cause an accident, damage or equipment destruction.

IF THE DEVICE IS NOT USED ACCORDING TO THE MANUAL THE USER IS RESPONSIBLE FOR POSSIBLE DAMAGES.



- This symbol denotes especially important characteristics of the unit. Read any information regarding this symbol carefully

1. BASIC REQUIREMENTS AND USER SAFETY



- **The manufacturer is not responsible for any damages caused by inappropriate installation, not maintaining the proper environmental conditions and using the unit contrary to its assignment.**
- Installation should be conducted by qualified personnel . During installation all available safety requirements should be considered. The fitter is responsible for executing the installation according to this manual, local safety and EMC regulations.
- GND input of device should be connected to PE wire;
- The unit must be properly set-up, according to the application. Incorrect configuration can cause defective operation, which can lead to unit damage or an accident.
- **If in the case of a unit malfunction there is a risk of a serious threat to the safety of people or property additional, independent systems and solutions to prevent such a threat must be used.**
- **The unit uses dangerous voltage that can cause a lethal accident. The unit must be switched off and disconnected from the power supply prior to starting installation of troubleshooting (in the case of malfunction).**
- Neighbouring and connected equipment must meet the appropriate standards and regulations concerning safety and be equipped with adequate overvoltage and interference filters.
- **Do not attempt to disassemble, repair or modify the unit yourself. The unit has no user serviceable parts. Defective units must be disconnected and submitted for repairs at an authorized service centre.**



- In order to minimize fire or electric shock hazard, the unit must be protected against atmospheric precipitation and excessive humidity.
- Do not use the unit in areas threatened with excessive shocks, vibrations, dust, humidity, corrosive gasses and oils.



- Do not use the unit in areas where there is risk of explosions.
- Do not use the unit in areas with significant temperature variations, exposure to condensation or ice.
- Do not use the unit in areas exposed to direct sunlight.
- Make sure that the ambient temperature (e.g. inside the control box) does not exceed the recommended values. In such cases forced cooling of the unit must be considered (e.g. by using a ventilator).



The unit is designed for operation in an industrial environment and must not be used in a household environment or similar.

2. GENERAL CHARACTERISTICS

Weight meter **SWI-94** is designed for cooperation with load cells (strain gages) in application not required to be approved. Device is equipped with push-buttons allow easy setting of tare and zero, and also switching between nett and gross indications. Measured weight is displayed on 6-digit readable LED display. The device can be equipped with two relay outputs or two OC-type outputs and one of following: active current output, passive isolated current output, active voltage output, which allow to use as controller for simple systems with batching function. Build in analogue output and RS-485 interface enable remote controlling of the device by a host system if required. The device software allows to use two calibration methods: data sheet calibration, or dead weight calibration. All critical states of the device are signalised by proper error messages.

3. TECHNICAL DATA

Power supply voltage (depending on version)	85... 230 ...260V AC/DC; 50 ÷ 60 Hz (separated) or 19... 24 ...50V DC; 16... 24 ...35V AC (separated)
External fuse (required)	T - type, max. 2 A
Power consumption	max. 4.5 VA @ 85 ÷ 260V AC/DC max. 4.5 VA @ 16V ÷ 35V AC max. 4.5 W @ 19V ÷ 50V DC

Measurement input	tensometer, programmable sensitivity selectable up to 2 mV/V or 4 mV/V
Load cells power supply	4.6 V ± 10%, I _{max} ~ 60 mA
Load cells connections	6-wire technique, min. resultant impedance of 80 Ω (e.g. 4 load cells 320 Ω)
Max. display divisions	10 000 d
Tare range	100% of selected measurement range

Programmable input	separated
Low level	0V ÷ 1V
High level	10V ÷ 30V (about 5.5mA @ 24V)
Sensor power supply output	24V +5%, -10% / max. 100 mA, stabilized
Relay output	0 or 2 NO 1A/250V AC (cos φ = 1)
OC-type output	0 or 2; 30mA / 30VDC / 100mW
Active current output (optional)	range max. 0 ÷ 24 mA
Load resistance max.	700 Ω
Passive isolated current output (optional)	range max. 2.8 ÷ 24 mA
Supply voltage	Us = 9.5 ÷ 36V
Load resistance max.	(Us – 9.5V) / 24mA [kΩ]
Active voltage output (optional)	range max. 0 ÷ 11V
Load resistance min.	2000 Ω
Display range	-99999 ÷ 999999, plus decimal point
Communication interface	RS 485, 8N1 and 8N2, Modbus RTU, not separated
Baud rate	1200 bit/s ÷ 115200 bit/s
Display	LED, 6 digit, 13mm height, red
Data memory	non-volatile memory, EEPROM type
Protection level	IP 65 optional version with panel cut-out sealing available
Terminals protection	IP 20

Housing type	panel
Housing material	NORYL - GFN2S E1
Housing dimensions	96 x 48 x 100 mm
Mounting hole	90.5 x 43 mm
Assembly depth	102 mm
Panel thickness	max. 5 mm
Operating temperature (depending on version)	0°C to +50°C or -20°C to +50°C
Storage temperature (depending on version)	-10°C to +70°C or -20°C to +70°C
Humidity	5 to 90% no condensation
Altitude	up to 2000 meters above sea level
Screws tightening max. torque	0.5 Nm
Max. connection leads diameter	2.5 mm ²
Safety requirements	according to: PN-EN 61010-1 installation category: II pollution degree: 2 voltage in relation to ground: 300V AC insulation resistance: >20MΩ insulation strength between power supply and input/output terminal: 1min. @ 2300V insulation strength between relays terminal: 1min. @ 1350V
EMC	according to: PN-EN 61326-1



This equipment is not intended for use in residential environments and may not provide adequate protection to radio reception in such environments.

4. DEVICE INSTALLATION

The unit has been designed and manufactured in a way assuring a high level of user safety and resistance to interference occurring in a typical industrial environment. In order to take full advantage of these characteristics installation of the unit must be conducted correctly and according to the local regulations.



- Read the basic safety requirements on page 3 prior to starting the installation.
- Ensure that the power supply network voltage corresponds to the nominal voltage stated on the unit's identification label.
- The load must correspond to the requirements listed in the technical data.
- All installation works must be conducted with a disconnected power supply.
- Protecting the power supply clamps against unauthorized persons must be taken into consideration.

4.1. UNPACKING

After removing the unit from the protective packaging, check for transportation damage. Any transportation damage must be immediately reported to the carrier. Also, write down the unit serial number on the housing and report the damage to the manufacturer.

Attached with the unit please find:

- user's manual,
- warranty,
- assembly brackets - 2 pieces.

4.2. ASSEMBLY



- The unit is designed for mounting inside housings (control panel, switchboard) insuring appropriate protection against surges and interference. Metal housings must be connected to ground in a way that complies with the governing regulations.
- Disconnect the power supply prior to starting assembly.
- Check the connections are wired correctly prior to switching the unit on.



In order to install the unit, a 90.5 x 43 mm mounting hole (**Figure 4.1, 4.6**) must be prepared. The thickness of the material of which the panel is made must not exceed 5mm. When preparing the mounting hole take the grooves for catches located on both sides of the housing into consideration (**Figure 4.1, 4.6**). Place the unit in the mounting hole inserting it from the front side of the panel, and then fix it using the brackets (**Figure 4.3**). The minimum distances between the centre points of multiple units - due to the thermal and mechanical conditions of operation - are 115 mm x 67mm (**Figure 4.2**).

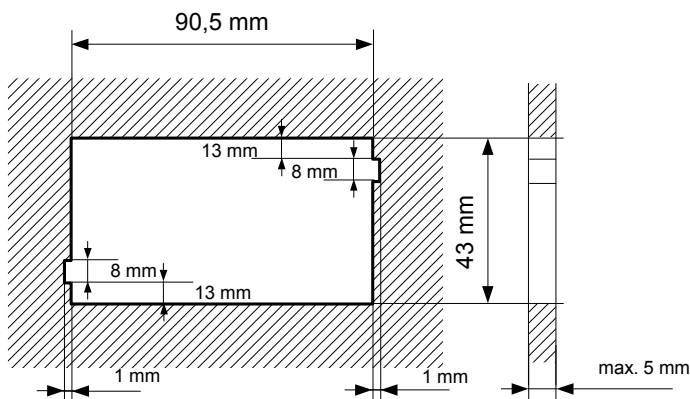

Figure 4.1. Recommended mounting hole dimensions

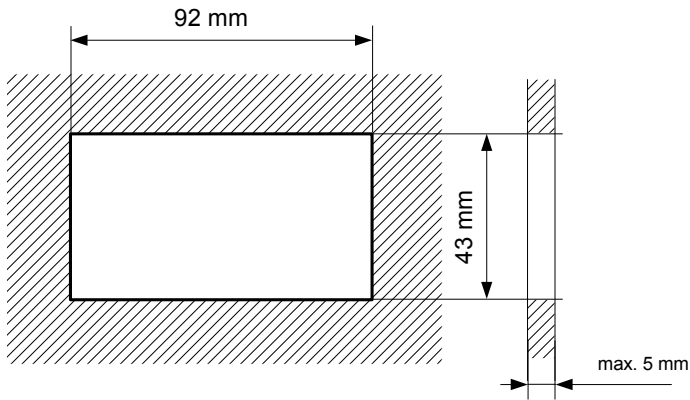

Figure 4.2. Allowable mounting hole dimensions

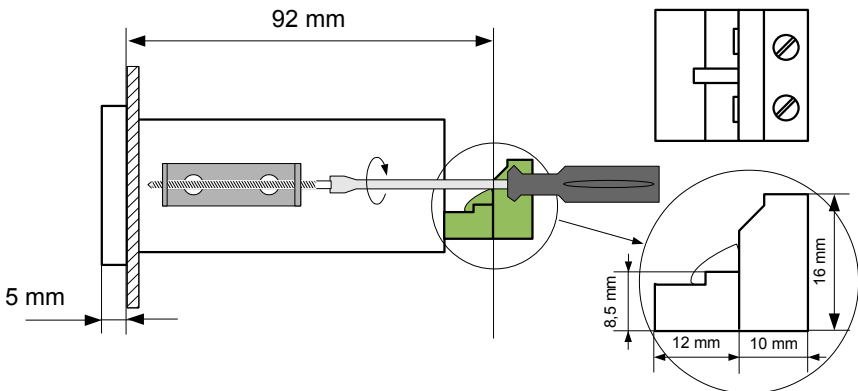

Figure 4.3. Installing of brackets, and dimensions of connectors.

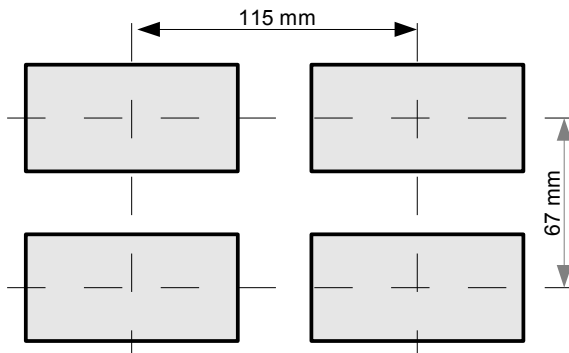

Figure 4.4. Minimum distances when assembly of a number of units



- The unit is designed for mounting inside housings (control panel, switchboard) insuring appropriate protection against surges and interference. Metal housings must be connected to ground in a way that complies with the governing regulations.
- Disconnect the power supply prior to starting assembly.
- Check the connections are wired correctly prior to switching the unit on.



In order to install the unit, a 90.5 x 43 mm mounting hole (**Figure 4.5, 4.6**) must be prepared. The thickness of the material of which the panel is made must not exceed 5mm. When preparing the mounting hole take the grooves for catches located on both sides of the housing into consideration (**Figure 4.5, 4.6**). Place the unit in the mounting hole inserting it from the front side of the panel, and then fix it using the brackets (**Figure 4.7**). The minimum distances between the centre points of multiple units - due to the thermal and mechanical conditions of operation - are 115 mm x 67mm (**Figure 4.8**).

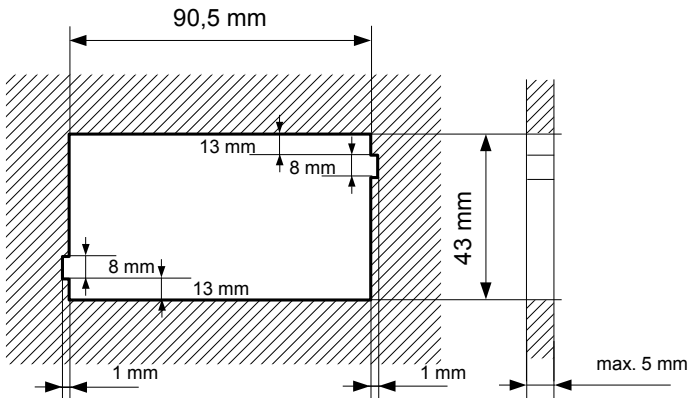

Figure 4.5. Recommended mounting hole dimensions

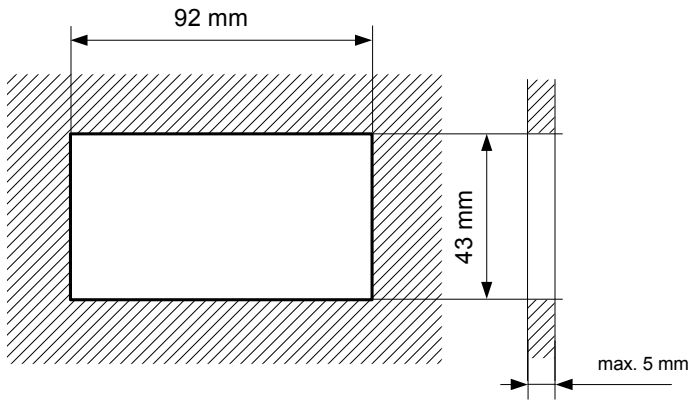

Figure 4.6. Allowable mounting hole dimensions

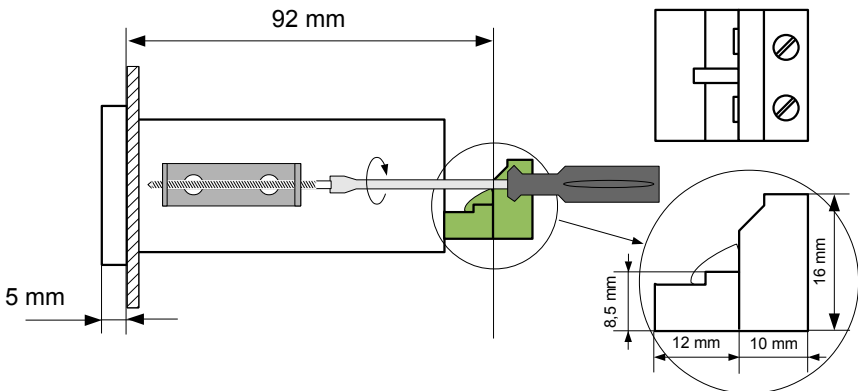

Figure 4.7. Installing of brackets, and dimensions of connectors.

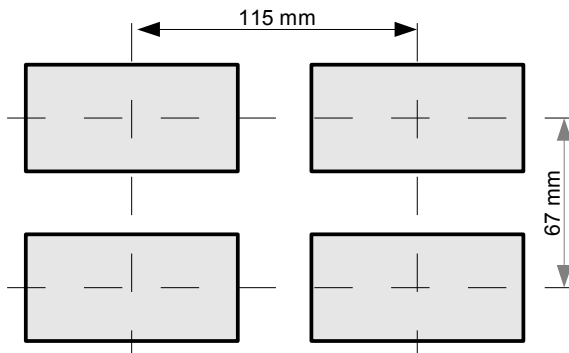

Figure 4.8. Minimum distances when assembly of a number of units

4.3. CONNECTION METHOD

Caution



- Installation should be conducted by qualified personnel . During installation all available safety requirements should be considered. The fitter is responsible for executing the installation according to this manual, local safety and EMC regulations.
- The unit is not equipped with an internal fuse or power supply circuit breaker. Because of this an external time-delay cut-out fuse with minimal possible nominal current value must be used (recommended bipolar, max. 2A) and a power supply circuit-breaker located near the unit. In the case of using a monopolar fuse it must be mounted on the phase cable (L).
- The power supply network cable diameter must be selected in such a way that in the case of a short circuit of the cable from the side of the unit the cable shall be protected against destruction with an electrical installation fuse.
- Wiring must meet appropriate standards and local regulations and laws.
- In order to secure against accidental short circuit the connection cables must be terminated with appropriate insulated cable tips.
- Tighten the clamping screws. The recommended tightening torque is 0.5 Nm. Loose screws can cause fire or defective operation. Over tightening can lead to damaging the connections inside the units and breaking the thread.
- In the case of the unit being fitted with separable clamps they should be inserted into appropriate connectors in the unit, even if they are not used for any connections.
- **Unused clamps (marked as n.c.) must not be used for connecting any connecting cables (e.g. as bridges), because this can cause damage to the equipment or electric shock.**
- If the unit is equipped with housing, covers and sealing packing, protecting against water intrusion, pay special attention to their correct tightening or clamping. In the case of any doubt consider using additional preventive measures (covers, roofing, seals, etc.). Carelessly executed assembly can increase the risk of electric shock.
- After the installation is completed do not touch the unit's connections when it is switched on, because it carries the risk of electrical shock.

Due to possible significant interference in industrial installations appropriate measures assuring correct operation of the unit must be applied. To avoid the unit of improper indications keep recommendations listed below.

- Avoid common (parallel) leading of signal cables and transmission cables together with power supply cables and cables controlling induction loads (e.g. contactors). Such cables should cross at a right angle.
- Contactor coils and induction loads should be equipped with anti-interference protection systems, e.g. RC-type.

- Use of screened signal cables is recommended. Signal cable screens should be connected to the earthing only at one of the ends of the screened cable.
- In the case of magnetically induced interference the use of twisted couples of signal cables (so-called "spirals") is recommended. The spiral (best if shielded) must be used with RS-485 serial transmission connections.
- In the case of measurement or control signals are longer than 30m or go outside of the building then additional safety circuits are required.
- In the case of interference from the power supply side the use of appropriate anti-interference filters is recommended. Bear in mind that the connection between the filter and the unit should be as short as possible and the metal housing of the filter must be connected to the earthing with largest possible surface. The cables connected to the filter output must not run in parallel with cables with interference (e.g. circuits controlling relays or contactors).

Connections of power supply voltage and measurement signals are executed using the screw connections on the back of the unit's housing.

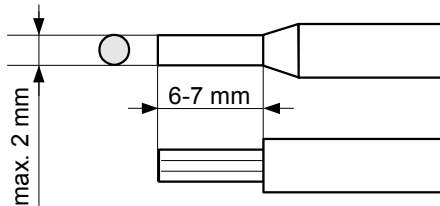

Figure 4.9. Method of cable insulation replacing and cable terminals



All connections must be made while power supply is disconnected !

Notes related to connection of strain bridges:



- Installation should be made according to local safety and electromagnetic compatibility regulations. While installation pay special attention to:
- use of shielded wires,
- shield of wires should be connected with metal housing using a conductive glands or metal clamp to ensure proper electrical contact.
- shielded wires should be mounted as close metal case of the device (e.g. connection box) as possible, and as far from disturbing wires (e.g. powering motors) as possible.

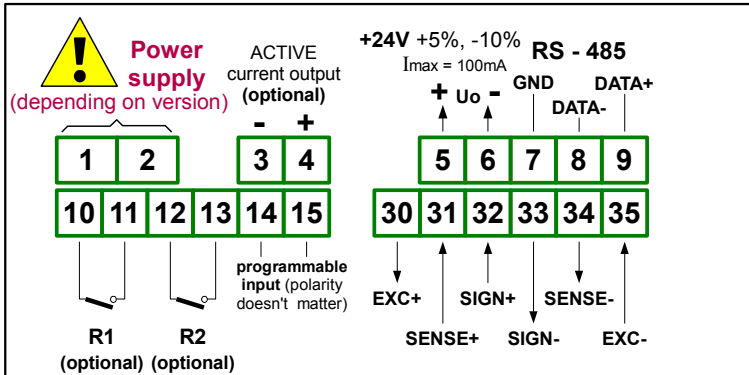

Figure 4.10. Terminals description (relay and active current outputs)

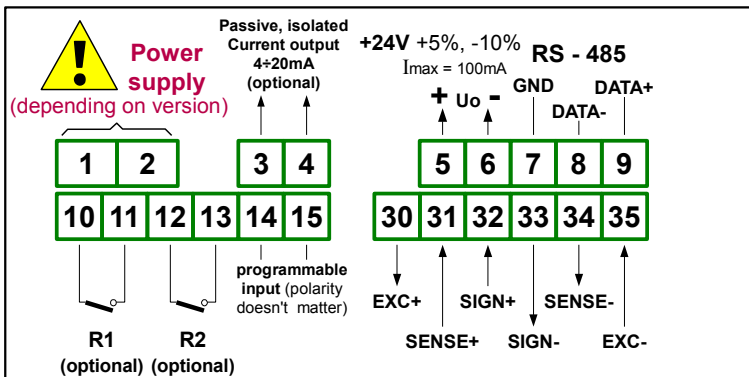

Figure 4.11. Terminals description (relay and passive current outputs)

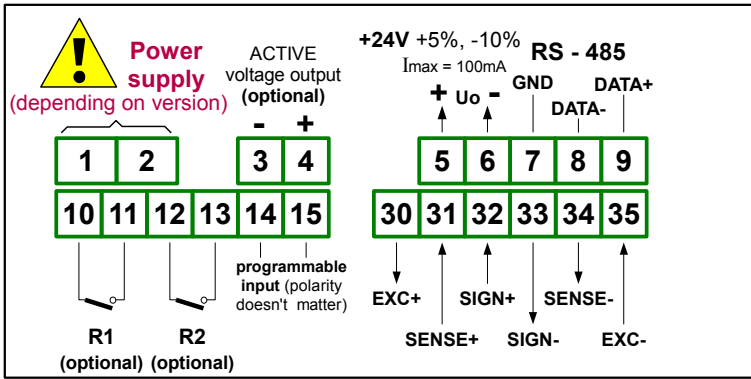

Figure 4.12. Terminals description (relay and active voltage outputs)

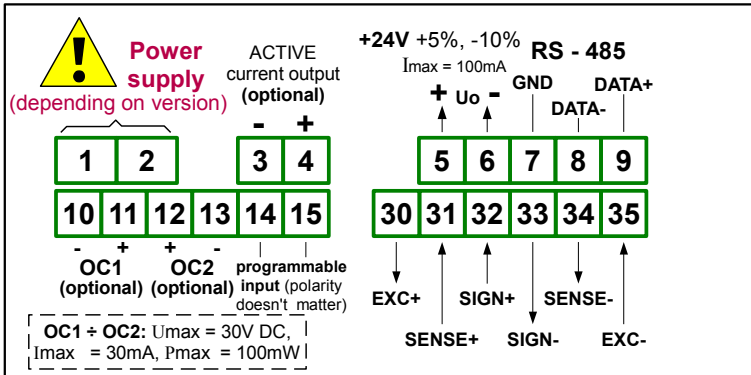

Figure 4.13. Terminals description (OC-type and active current outputs)

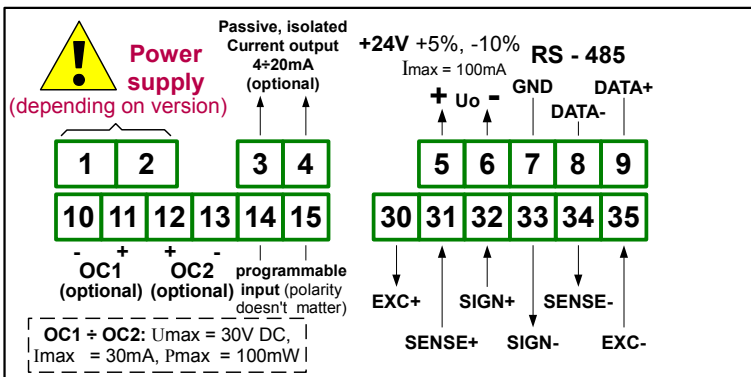

Figure 4.14. Terminals description (OC-type and passive current outputs)

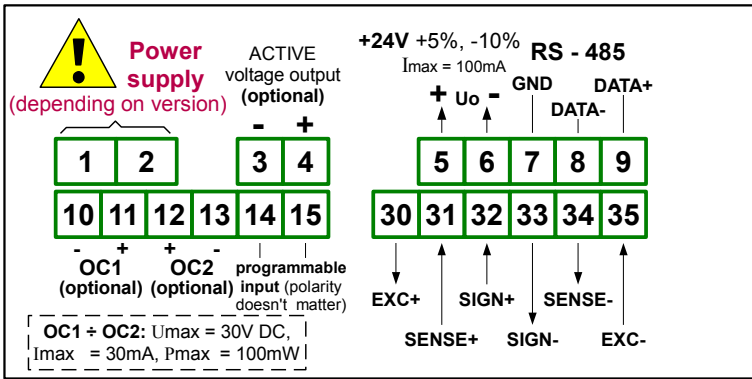

Figure 4.15. Terminals description (OC-type and active voltage outputs)

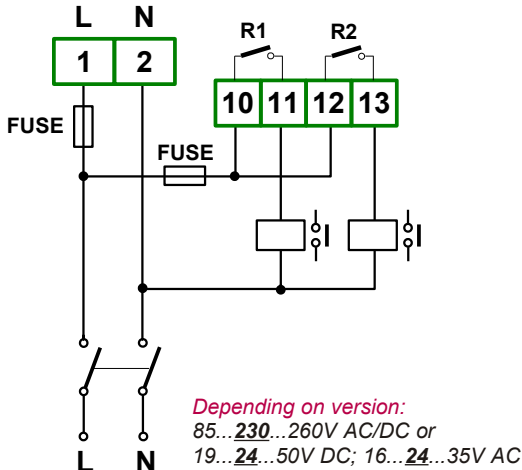

Figure 4.16. Connection of power supply and relays



Contacts of relay outputs are not equipped with spark suppressors. While use the relay outputs for switching of inductive loads (coils, contactors, power relays, electromagnets, motors etc.) it is required to use additional suppression circuit (typically capacitor 47nF/ min. 250VAC in series with 100R/5W resistor), connected in parallel to relay terminals or (better) directly on the load. In consequence of using the suppression circuit, the level of generated electromagnetic disturbances is lower, and the life of relay contacts rises.

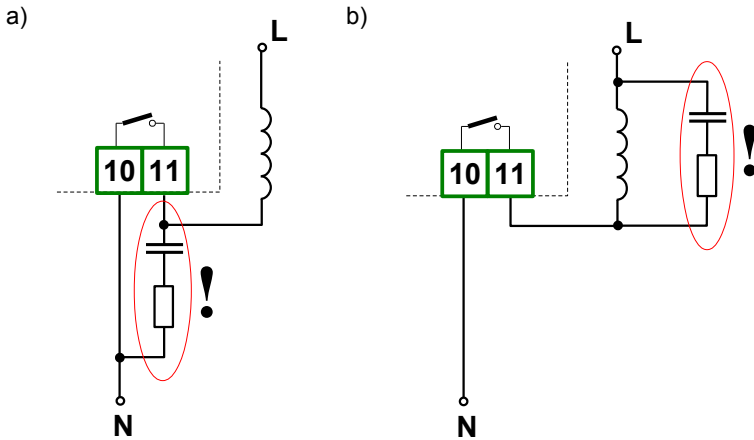

Figure 4.17. Examples of suppression circuit connection:
a) to relay terminals; b) to the inductive load

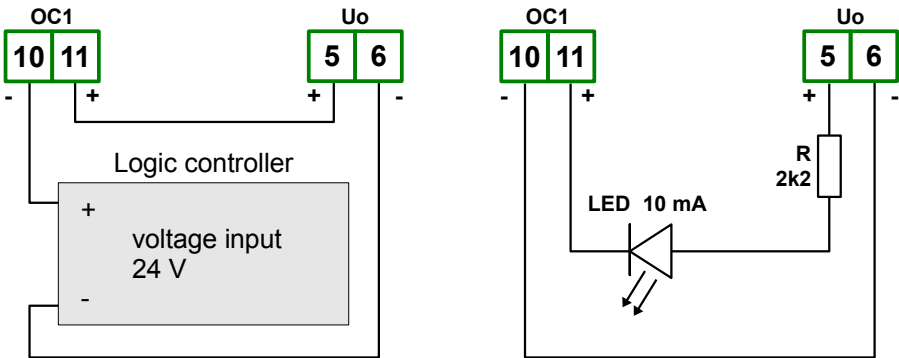

Figure 4.18. Example of OC-type outputs connection

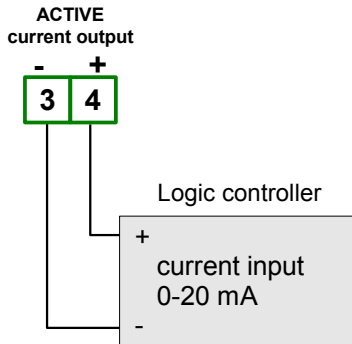

Figure 4.19. Example of active current outputs connection
(for device with active current output only)

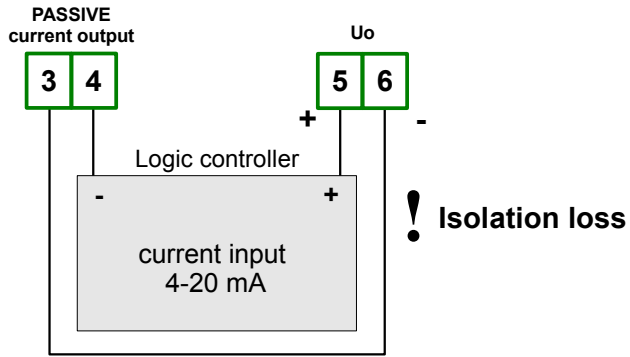

Figure 4.20. Example of passive current outputs connection (for device with passive current output only)

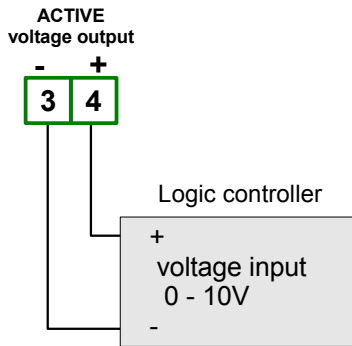
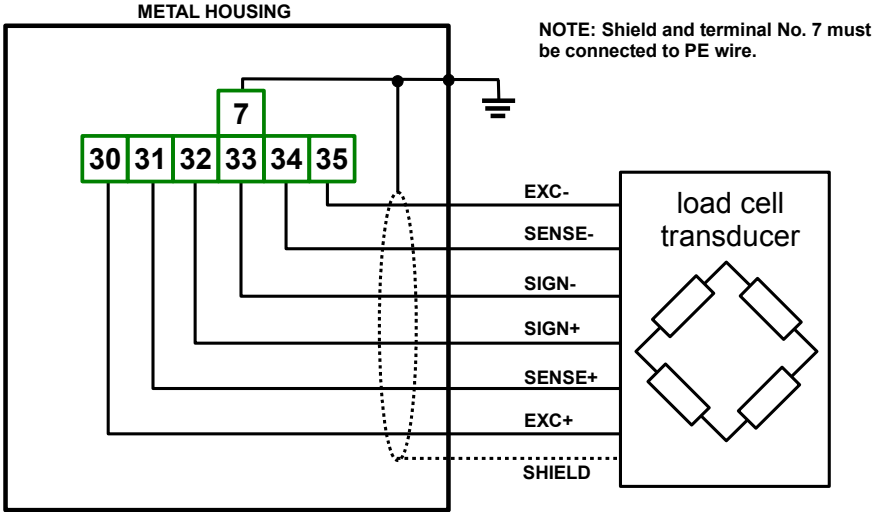
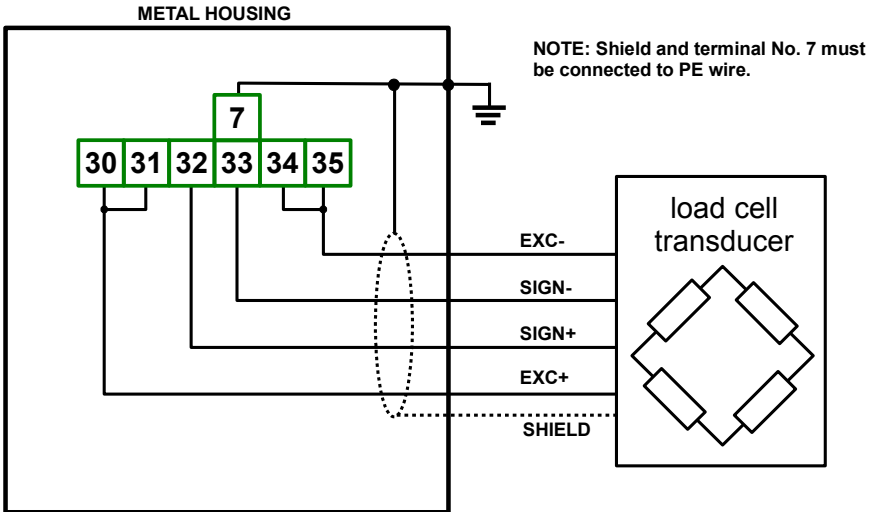

Figure 4.21. Example of active voltage outputs connection (for device with active voltage output only)



Rys. 4.22. Example of 6-wire load cell connection.



Rys. 4.23. Example of 4-wire load cell connection.

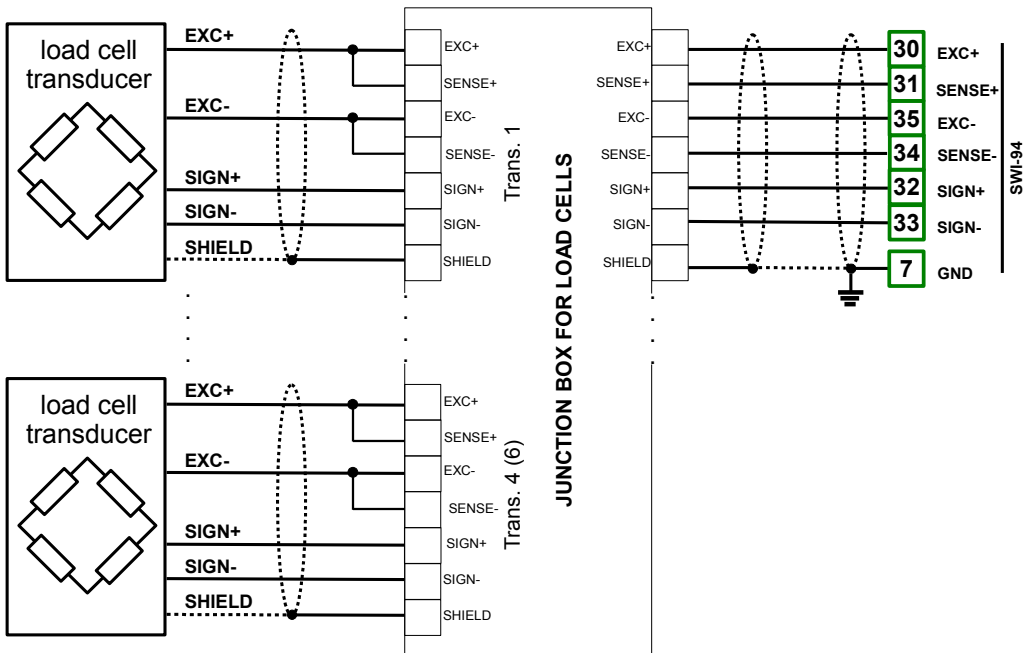

Rys. 4.24. Example of several 4-wire load cells connection using junction box.

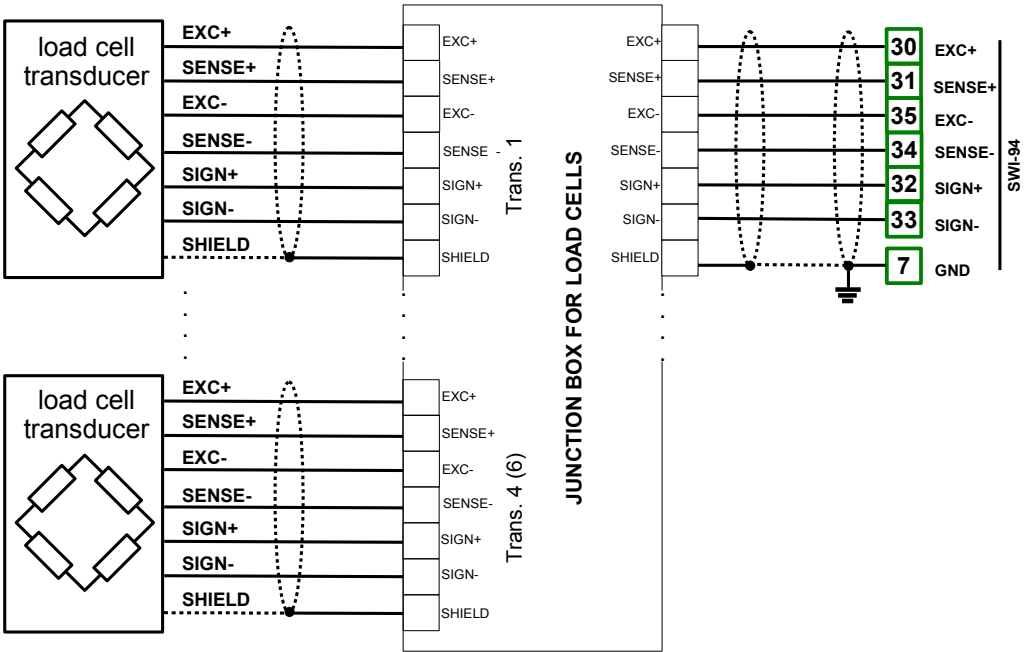

Rys. 4.25. Example of several 6-wire load cells connection using junction box.

4.4. MAINTENANCE

The unit does not have any internal replaceable or adjustable components available to the user. Pay attention to the ambient temperature in the room where the unit is operating. Excessively high temperatures cause faster ageing of the internal components and shorten the fault-free time of unit operation.

In cases where the unit gets dirty do not clean with solvents. For cleaning use warm water with small amount of detergent or in the case of more significant contamination ethyl or isopropyl alcohol.



Using any other agents can cause permanent damage to the housing.



Product marked with this symbol should not be placed in municipal waste. Please check local regulations for disposal and electronic products.

5. FRONT PANEL DESCRIPTION

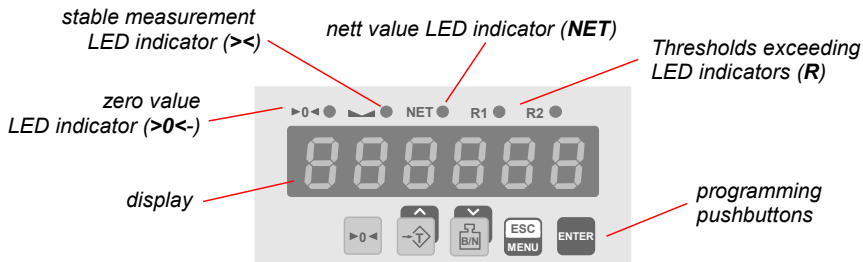

Symbols and functions of push-buttons:



Symbol used in the manual: **[ESC/MENU]**

Functions:

- Enter to main menu (press and hold by at least 2 sec.)
- Exit the current level and Enter to previous menu (or measure mode)
- Cancel the changes made in parameter being edited



Symbol used in the manual: **[ENTER]**

Functions:

- Start to edit the parameter
- Enter to the sub-menu,
- Confirmation of changes made in parameter being edited.



Symbol used in the manual: **[^]** or **[T]**

Functions:

- Tare
- Change of the present menu,
- Modification of the parameter value,
- Change of the display mode.



Symbol used in the manual: **[v]** or **[B/N]**

Functions:

- Switch between gross/nett value
- Change of the present menu,
- Modification of the parameter value,
- Change of the display mode.



Symbol used in the manual: **[>0<]**

Functions:

- zeroing displayed value.

6. PRINCIPLE OF OPERATION

After turning the power supply on, device ID and software version are showed on the display, next the controller goes to the measurement mode.

6.1. MEASUREMENT MODE

While device is in measurement mode LED display shows gross or net weight. Net weight presentation mode is signalized by LED marked „**NET**”. If the weight is constant while 10 successive measurements then it is signalized by LED marked „**><**” (stable measurement). LED diode marked „**>0<**” signalizes that result of measurement is zero.

Zeroing of the scale is possible by pressing [**>0<**] button, but only when current weight do not exceeds 2% of full range, and measurement is stable (LED „**><**” is lighted). Pressing of [**T**] button causes storing of current value as tare weight, after that device goes to displaying net weight. Pressing of [**B/N**] button causes alternative change of presentation mode (gross - net weight).

Device recalculates measurement results according to calibration factors entered by a user using „**CALibr**” menu. **Nominal measurement range** is 2 mV/V or 4 mV/V (depend on value of „**rAnGE**” parameter in „**CALibr**” menu).

If the result of measurement exceeds the **nominal measurement range**, a warning „**Hi**” or „**Lo**” is displayed in place of measurement value, depends on exceeded value. All other warnings are displayed in numerical or text form (see chapter **SIGNALISATION OF ERRORS**).



If the measurement value do not exceeds nominal measurement range but displayed value exceeds range $-99999 \div 999999$, the warning „**-Over-**” is displayed rather than the calculated result.

In the measurement mode user can check main thresholds values. After pressing [**ENTER**] button, name of the threshold „**rELPr1**” and his value will be displayed on the display in alternating mode. If [**^**] or [**v**] will be pressed in 5 sec again, the next threshold will be displayed, else the device comes back to the measurement mode. If a **free access** is enabled (see description of „**SECur**” menu), user can change the value of particular threshold pressing button [**ENTER**] once again(see: **PARAMETERS EDITION**).

All accessible parameters can be changed by entering the menu (see: **DEVICE PROGRAMMING**). Use the local keyboard or the remote controller to do it. (Note: all parameters can be remote changed via RS-485 interface).



Configuration of the device (via menu or RS 485 interface) **do not stops measures**.

6.2. DETECTION OF THE PEAK VALUES

The **SWI-94** weight meter is equipped with peaks detection function. It can detect a peaks of the input signal and display their values. Presets connected with this function are placed in **"HOLD"** menu (see description of **"HOLD" menu**). The detection of the peak can be done if the measured signal raises and drops of value at least equal to parameter **"PEA"**. Detected peaks are displayed during the time defined by parameter **"time"**. If a new peak will be detected while one is displayed, this new peak will be displayed and display time counter will be cleared (**Figure 6.1**). If no peaks are detected while time **"time"** elapses, device starts to show the current value of input signal again. If „**H diSP**"=**"HOLD"** then setting parameter **"time"**=**0.0** causes holding peak value until **[ESC]** button is pressed. If „**H diSP**"=**"REAL"** then value **"time"**=**0.0** means no holding. Displaying peak value is signalized by flashing most right decimal point.

The relays/LEDs and the analogue output can be controlled depending on the current value of input signal or the peak value (see **"HOLD" menu**).

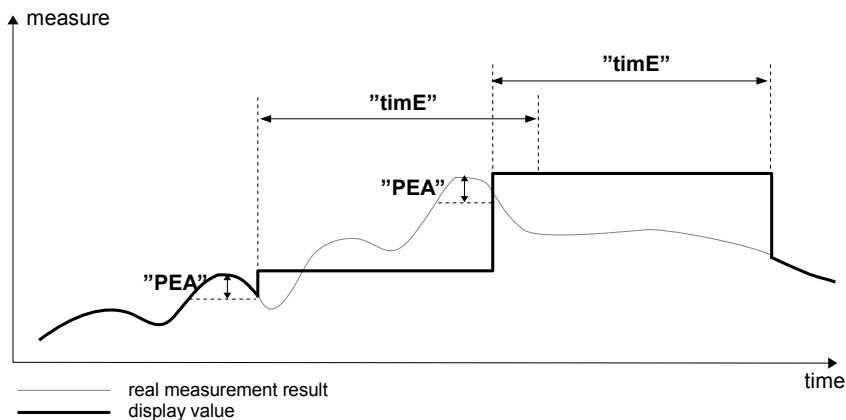

Figure 6.1. Process of peaks detection

6.3. CONTROL OF THE RELAY OUTPUTS

The control of the object (measured signal) is done due to gross or nett value (depending on "SourCE" parameter), and is realized via relay outputs. Front panel LEDs named „R" indicates the state of particular relay output.

Modes of the control can be changed depend on the values of parameters "SourCE", "SEt P", "SEt P2", "HYSt", "modE", "t on", "t oFF", "unit" and "ALArMS". Depend on "modE" parameter, relays can be not used or controlled over one or two thresholds values.

If one threshold is used (Figure 6.2) the relay can be turned on ("modE" = "on") or off ("modE" = "oFF") when the input signal value is contained in **zone A**. If two thresholds are used (Figure 6.3) the relay will be turned on when value of input signal is contained in **zone A** ("modE" = "in") or **zone B** ("modE" = "out") and turned off if the signal is contained in the second one.

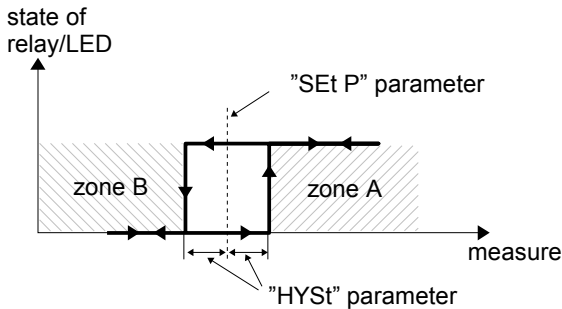

Figure 6.2. One threshold control of the relay/LED outputs

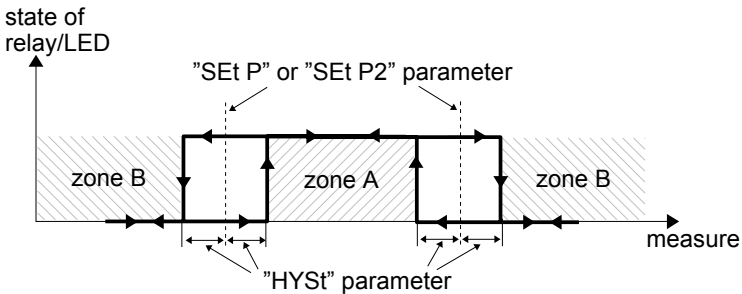
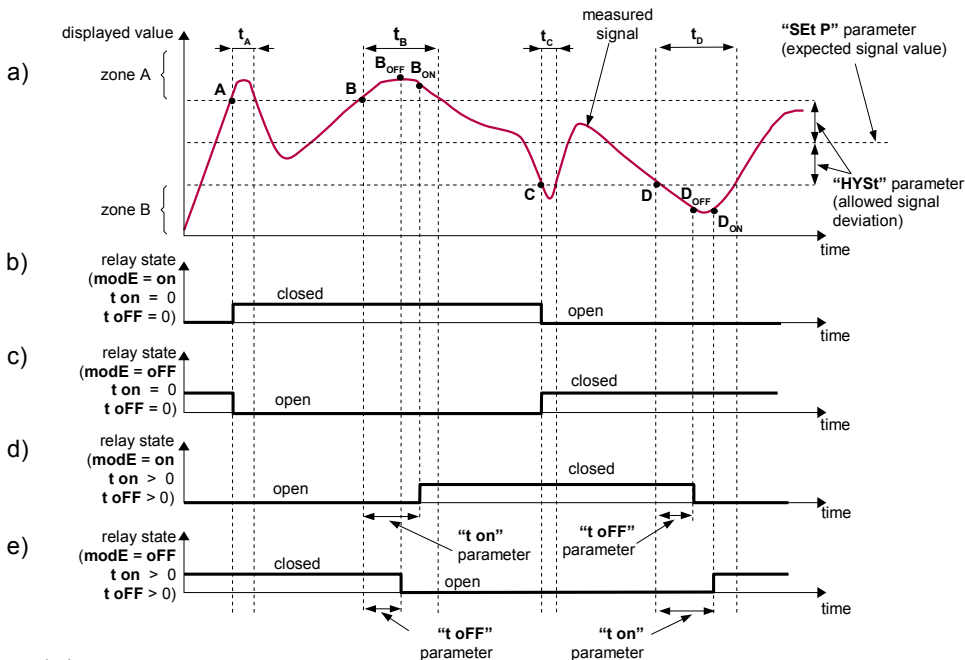

Figure 6.3. Two threshold control of the relay/LED outputs

6.3.1. One threshold mode

Figure 6.4 presents the principle of relay outputs operation for one threshold mode, and an example values of other parameters.



Description:

A, B, C, D - points where measured signal exceeds border values (expected value \pm allowed deviation)

B_{ON}, B_{OFF}, D_{ON}, D_{OFF} - relays state changes moments: (for "t on" > 0, "t off" > 0)

t_A, t_B, t_C, t_D - time periods while input signal is in zone A or zone B

Figure 6.4. Principle of LED/relay output operation for one threshold mode

"SEt P" parameter sets a **threshold** of the relay, and parameter "HYSt" sets a **hysteresis** of the relay (graph: a). The relay can change his state when input value is equal to or greater than (over or under) **border value** (means values equal to **threshold+hysteresis** and **threshold-hysteresis** respectively) and t_A, t_B, t_C, t_D times are bigger than the time defined by parameters "t on", "t off" and "unit". If "t on" and "t off" parameters are set to "0", then the relay state will be changed **as soon** as input value exceeds any of the **border values** (see points A and C, graphs: a, b, c).

If values of "t on" or/and "t off" are positive, then relay state will be turned on if the input value is equal to or greater than the **border values** and stays like that during at least "t on" (see points B_{ON}, D_{ON}, graph a, d, e). Similarly, the relay will be turned off if time "t off" elapse since the input signal value is equal to or greater than the **border values** (see points B_{OFF}, D_{OFF}, graph: a, d, e).

If t_A , t_B , t_C or t_D (when input signal stay in **zone A** or **zone B**) are lower than parameters “**t on**” or “**t off**”, the relay will not change his state (see points A and C, graph: a, d, e). The state of relay output while the input value exceeds the **border values** (points A, B, C, D) is described by parameter “**mode**”. The relay can be turned on (“**mode**” = “**on**”), or turned off (“**mode**” = “**off**”) when input signal value is contained in **zone A** (graph: a).

The parameter “**ALARMS**” allow user to set the relay output behaviour in critical situations (e. g. Input values exceeds **permissible measurement range**). User can select that the relays will be turned on, turned off, or not changed in critical situations.

All parameters connected with relay outputs are described in paragraph “**rELAY1**” menu.

6.3.2. Two thresholds mode

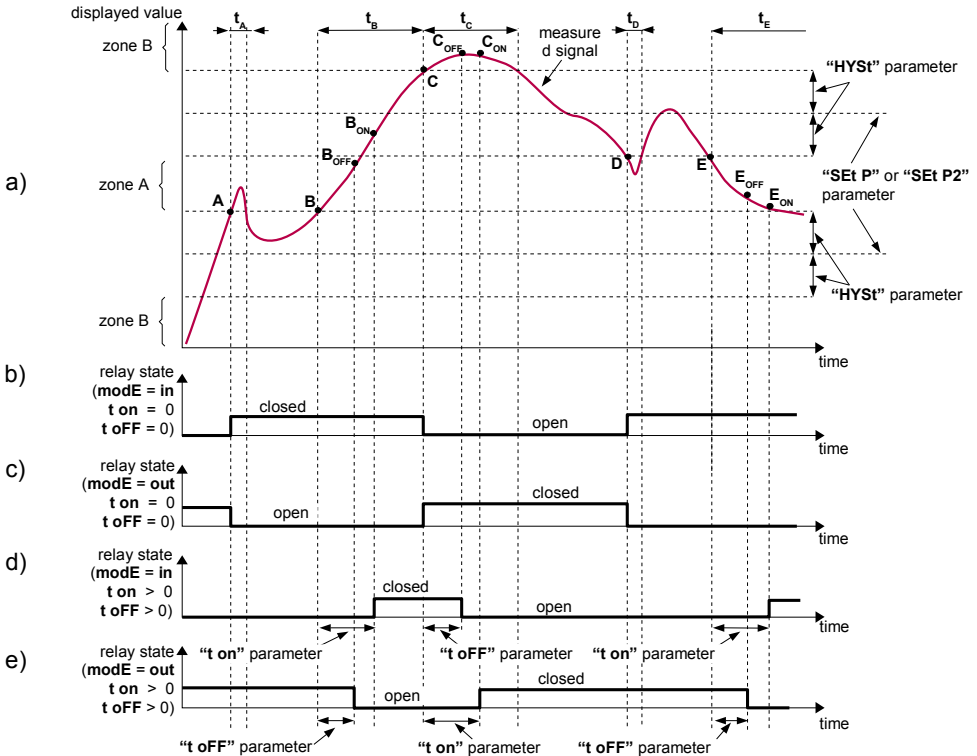

Description:

- A, B, C, D, E** - points where measured signal exceeds border values (expected value \pm allowed deviation)
- B_{ON}, B_{OFF}, C_{ON}, C_{OFF}, E_{ON}, E_{OFF}** - relays state changes moments: (for “**t on**” > 0, “**t off**” > 0)
- t_A, t_B, t_C, t_D, t_E** - time periods while input signal is in zone A or zone B

Figure 6.5. Principle of LED/relay output operation for two thresholds mode

Figure 6.5 presents the principle of relay outputs operation for two thresholds mode, and an example values of other parameters. In this mode parameter **"SEt P2"** is accessible in common with **"SEt P1"**, this parameter describes a second threshold of the relay output. The parameters **"HYSt"**, **"mode"**, **"t on"**, **"t OFF"**, **"unit"** and **"ALArms"** are connected with both **"SEt P1"** and **"SEt P2"** thresholds. While the controlling process, the relay output changes his state depends of both **"SEt P1"** and **"SEt P2"** thresholds in similar way as it was described in one threshold mode (for more details see **Tab.7.1**). Time parameters like **"t on"**, **"t OFF"** and **"unit"** also affects both thresholds.

If two threshold mode is used, **"mode"** parameter defines state of the relay output when the input value occurs in a particular zone defined by **border values** of both **thresholds**. The relay can be turned on if the input value is contained in **zone A** (**"mode"** = "in") or **zone B** (**"mode"** = "out") and turned off if it is contained in the second one (**Figure 6.5**).



Control of relay outputs depends on difference between thresholds values (**zone A**) and outside of threshold values (**zone B**). But the order of the thresholds is important if **"HYSt"** parameter is equal zero (see **Tab.7.1**).

7. DEVICE PROGRAMMING

The device menu allow user to set all parameters connected to operation of measurement input, control modes, critical situations behaviour, communication via RS-485 and access settings. The meaning of the particular parameters is described in paragraph **MENU DESCRIPTION**.

Some of the parameters can be accessed without menu entering (quick view mode). After pressing **[ENTER]** button, name of the threshold ("**rELPr1**") and his value will be displayed on the display in alternating mode. If **[^]** or **[v]** will be pressed in 5 sec, the next threshold will be displayed, else the device comes back to the measurement mode. If a **free access** is enabled (see description of **"SECUR"** menu), user can change the value of particular threshold pressing button **[ENTER]** (see: **PARAMETERS EDITION**).



If particular parameter has been changed and confirmed in quick view mode, its new value is displayed in alternating mode with parameter name by few seconds. Confirmed changes may be checked or user can switch viewed parameter pressing **[^]** or **[v]** button.

7.1. PROGRAMMING MENU

To enter main menu (being in the measurement mode) operator must to press and hold at least 2 sec. **[ESC/MENU]** button.

If the user password is defined (see parameter **"SEtCod"**, menu **"SECUR"**), operator have to enter correct one before proceeding to menu options . Entering of the passwords is similar to the edition of numeric parameters (see: **PARAMETERS EDITION**), however presently editing digit is showed only on the display, other digits are replaced by "-" sign.

After entering of last digit of the password first menu position will be displayed (if the password is correct) or warning **"Error"** in other case.



Pay attention when device parameters are being changed. If it is possible, turn off controlled installation (machine).

Functions of the buttons while sub-menu and parameters choice:

Selection of sub-menu or parameter for editing. Name of selected item (sub-menu or parameter) is displayed.



Operation of **[ENTER]** button depend on present menu position:

- if the name of some sub-menu is displayed - enter this sub-menu; name of the first parameter (or next level sub-menu) is displayed,
- if the name of some parameter is displayed - enter the edition of this parameter; present value of the parameter is displayed,



[ESC/MENU] button allow user to exit present menu level and goes to upper level menu (or measurement mode).

7.2. PARAMETERS EDITION

To start edition of any parameter user should select name of desired one using **[^]** **[v]** buttons and then press **[ENTER]**.

7.2.1. Numeric parameters (digit change mode)

Numerical parameters are displayed as decimal numbers. The mode of its new value entering depends on chosen edit method (see parameter „**Edit**“).

In mode “by digit” („**Edit**“=“**dig**“) pressing one of the keys **[^]** or **[v]** causes change of current position (flashing digit) or the sign (+/-). Short pressing of the **[ENTER]** button causes change of the position (digit).

Press **[ENTER]** at least 2 seconds to accept the changes, after that question “**Set?**” is displayed, and user must to confirm (or cancel) the changes. To conform changes (and store it in EEPROM) press **[ENTER]** button shortly after “**Set?**” is displayed. To cancel the changes press **[ESC]** button shortly after “**Set?**” is displayed. After that device returns to the menu.

7.2.2. Numeric parameters (slide change mode)

In “slide change” mode („**Edit**“=“**Slid**“), buttons **[^]** and **[v]** has different functions.

To increase edited value press (or press and hold) **[^]** button only, the increasing became quickest as long as button **[^]** is pressed. To slow down the increasing, button **[v]** can be used. If **[v]** is pressed shortly (and button **[^]** is still pressed), increasing slow down for a moment only, if **[v]** is pressed and held while button **[^]** is still pressed the increasing slow down and will be kept on lower speed.

To decrease edited value press (or press and hold) **[v]** button only. The decreasing became quickest as long as button **[v]** is pressed. To slow down the decreasing, button **[^]** can be used. If **[^]** is pressed shortly (and button **[v]** is still pressed), decreasing slow down for a moment only, if **[^]** is pressed and held while button **[v]** is still pressed the decreasing slow down and will be kept on lower speed.

Press **[ENTER]** at least 2 seconds to accept the changes, after that question “**Set?**” is displayed, and user must to confirm (or cancel) the changes. To conform changes (and store it in EEPROM) press **[ENTER]** button shortly after “**Set?**” is displayed. To cancel the changes press **[ESC]** button shortly after “**Set?**” is displayed. After that device returns to the menu.

7.2.3. Switch parameters (“LIST” type)

Switch parameters can be described as a sets of values (a lists) out of which only one of the options available on the list can be selected for the given parameter. Options of switching parameter are selected using [^], [v] keys.

Short pressing of [ENTER] causes in displaying of the acknowledge question (“SEt?”). If key [ENTER] is pressed again, the changes are accepted, stored in EEPROM end the edition process finished. Pressing the key [ESC] after “SEt?” causes in cancelling of made changes and returning to menu.

Functions of buttons when editing numeric and switching parameters:



While editing numeric parameter:

- change of current (flashing) digit
 - slide change of value (acceleration, deceleration, direction change)
- While editing switch parameter - selection of switch parameter.



If numerical parameter is being edited, a short press of [ENTER] button change edited position. A long press of [ENTER] button (at least 2 sec.) causes of display a “SEt?” ask, which allow user to make sure if change of the parameter value is correct. If switch parameter is being edited, a short press of [ENTER] button causes of display a “SEt?” ask. When [ENTER] button is pressed again (while “SEt?” is displayed) the new value of the parameter is stored in EEPROM memory.



Pressing this button operator can cancel the changes done up to now (if they were not approved by [ENTER] button after the “SEt?” ask) and come back to menu

7.3. MENU DESCRIPTION

“- - - -” - password checking. If some password different from „0000” is set, then every enter to main menu follows the entering of password. If entered password is correct then first menu position will be displayed else warning “Error”, and unit returns to measurement mode.



Due to problem with direct displaying of “m” letter, it is exchanged with special sign “”. Independently in user manual letter „m” is used to make it more readable (example: “modE”).

7.3.1. “rELAy1” menu

This menu allows to configure the operation mode of relays and LEDs marked „R” (e.g. „R1”). If there are few relay outputs available, then every output has its own configuration menu (e.g. menu „rELAy2” for relay (LED) „R2”). Principle of the relays operation is described in paragraph 6.3. CONTROL OF THE RELAY OUTPUTS.

“Source” - parameter defining kind of result using to control state of this relay.
It can be set to one of two values:

- “GroSS”** - relay is controlled due to gross value of weight,
- “nEtt”** - relay is controlled due to nett value of weight.



The relays/LEDs can be controlled depending on the current value of input signal or the peak value (see **“HOLd” menu**).

“SEt P” - first threshold of the relay (range -99999 ÷ 999999). **Threshold is the medium value of relay hysteresis.**

“SEt P2” - second threshold of the relay (range -99999 ÷ 999999). This threshold is accessible when **“modE”** parameter is set to „in” or „out” value. **Threshold is the medium value of relay hysteresis.**

“HYSt” - hysteresis of relay (range 0 ÷ 99999). Full hysteresis of the relay is equal to 2x **“HYSt”** parameter. The relay state can change when an input signal is out of **threshold-hysteresis** to **threshold+hysteresis** zone.



Presented parameters should be set to ensure that **“SEt P” + “HYSt”**, **“SEt P2” + “HYSt”**, **“SEt P” - “HYSt”** or **“SEt P2” - “HYSt”** do not exceeds the measure range. Additionally, in two threshold mode (**“modE”**= „in” or „out”), the hysteresis for both thresholds must not cover each other (in other case relay can't change his state).

“modE” - relay operation mode. There are six options:

“noAct” - the relay is not active (permanent turned off)

“on” - one threshold mode, the relay is turned **ON** when input signal is greater than or equal to the threshold; detailed mode of action depends on **“SEt P”** and **“HYSt”** parameters settings and is shown in **Tab.7.1**,

“oFF” - one threshold mode, the relay is turned **OFF** when input signal is greater than or equal to the threshold; detailed mode of action depends on **“SEt P”** and **“HYSt”** parameters settings and is shown in **Tab.7.1**,

“in” - two thresholds mode; relays turns on when measured signal is between thresholds; detailed mode of action depends on **“SEt P”**, **“SEt P2”** and **“HYSt”** parameters settings and is shown in **Tab.7.1**,

“Out” - two thresholds mode; relays turns on when measured signal is outside the thresholds range; detailed mode of action depends on **“SEt P”**, **“SEt P2”** and **“HYSt”** parameters settings and is shown in **Tab.7.1**,

“modbuS” - the relay is controlled via RS-485 interface, independently on the input signal.

Mode:	Relay switches on when:	Relay switches off when:
„on”	$w \geq Pr_1$, $w \geq Pr + h$,	for $h=0$ for $h \neq 0$ $w < Pr$, $w \leq Pr - h$,
„oFF”	$w < Pr_1$, $w \leq Pr - h$,	for $h=0$ for $h \neq 0$ $w \geq Pr_1$, $w \geq Pr + h$,
„in” for $SEt P < SEt P2$	$Pr_1 \leq w \leq Pr_2$, $Pr_1 + h \leq w \leq Pr_2 - h$,	for $h=0$ for $h \neq 0$ $w < Pr_1 \vee w > Pr_2$, $w \leq Pr_1 - h \vee w \geq Pr_2 + h$,
„Out” for $SEt P < SEt P2$	$w < Pr_1 \vee w > Pr_2$, $w \leq Pr_1 - h \vee w \leq Pr_2 + h$,	for $h=0$ for $h \neq 0$ $Pr_1 \leq w \leq Pr_2$, $Pr_1 + h \leq w \leq Pr_2 - h$,
„in” for $SEt P > SEt P2$	$Pr_1 > w > Pr_2$, $Pr_1 - h \geq w \geq Pr_2 + h$,	for $h=0$ for $h \neq 0$ $w \geq Pr_1 \vee w \leq Pr_2$, $w \geq Pr_1 + h \vee w \leq Pr_2 - h$,
„Out” for $SEt P > SEt P2$	$w \geq Pr_1 \vee w \leq Pr_2$, $w \geq Pr_1 + h \vee w \leq Pr_2 - h$,	for $h=0$ for $h \neq 0$ $Pr_1 > w > Pr_2$, $Pr_1 - h \geq w \geq Pr_2 + h$,

Where:

Pr_1 – value in parameter **SEt P**,
 Pr_2 – value in parameter **SEt P2**,
 h – value in **HYSt** parameter,
 w – measured value,

Tab.7.1. Relay mode of action depending on modes and values in parameters “SEt P”, “SEt P2” and “HYSt”



- **LEDs light when relays are closed**, independently of relays' mode.
- When power supply fail, unit do not store relays state selected by RS-485 interface.

“t on” - turn on delay time, the relay is turned on with delay equal “t on” if the input value is equal to or greater than appropriate **border value** (defined with **threshold** and **hysteresis**), at least “t on” time. “t on” range 0 ÷ 99.9, defined with 0.1 sec. resolution. Unit of this parameter is set by “unit” parameter.

“t oFF” - turn off delay time, the relay is turned off with delay equal “t oFF” if the input value is equal to or greater than appropriate **border value** (defined with **threshold** and **hysteresis**), at least “t oFF” time. “t oFF” range 0 ÷ 99.9, defined with 0.1 sec. resolution. Unit of this parameter is set by “unit” parameter.



If time when the input signal is equal to or greater than some border value is shorter than “t on” or “t oFF” time, the relay do not change his state (see paragraph 6.3. **CONTROL OF THE RELAY OUTPUTS**).

“unit” - unit of time for “t on” and “t oFF” parameters. Can be set on one of two values:
“min” - minutes,
“SEC” - seconds.

“ALArMS” - this parameter defines the relay reaction when some critical situations occurs:

- “noCHAn”** - relay do not change his state,
“on” - relay will be turned on,
“oFF” - relay will be turned off.

If parameter **“modE”** is set to **“on”**, **“oFF”**, **“in”** or **“Out”** the “critical situation” means that **nominal input range** is exceeded.

If parameter **“modE”** is set to **“modbus”**, the “critical situation” means communication delay (when no data is received) longer than **“mbtimE”** parameter (see description: **“rS-485” menu**).



- If option **“noCHAn”** is selected for **“ALArMS”** parameter, behaviour of the relay may depend on **“FiltEr”** parameter in some cases. If **“FiltEr”** is set to big value and the input signal drops, result value of the measure will change slow, causes of turning on or off relay due to thresholds values. The critical situation is slowly detected, so it is impossible to predict the relay state in that situations.
- If parameter **„AL”** = **„on”**, the relay will be turned on in the critical situations, even if his parameter **“modE”** = **“noAC”**.

7.3.2. “bEEPEr” menu

This menu contains options connected with acoustic signal :

- “AL”** - if this parameter is set to **“on”**, any critical situation causes by acoustic signal
“r1” - if this parameter is set to **“on”**, activation of relay **R1** causes by acoustic signal
“r2” - if this parameter is set to **“on”**, activation of relay **R2** causes by acoustic signal



Acoustic signal (turned on by e.g. relay) can be turned off by pressing of any button.

7.3.3. “CALibr” menu

This menu contains options for measurement input calibration:

- “rESOL”** - display resolution of measurements, relays thresholds, and calibration values. Available values: 0.01; 0.02; 0.05; 0.1; 0.2; 0.5; 1; 2; 5; 10; 20; 50.



According to practical application circumstances (to get stable measurements) it is recommended to set **„rESOL”** parameter value according to selected measurement range. Set such value of **„rESOL”** to ensure that whole number of measurement divisions do not exceed permissible value (for theoretical calibration ratio of

„r LoAd” / “rESOL” < 10000, similarly while dead weight calibration ratio of **„LoAd” / “rESOL” < 10000**).

- “rAnGE”** - measurement input range, 2 mV/V or 4 mV/V. Set this range according to parameter Rated Output (R.O.) of strain bridge.

"C tYPE" - calibration type. Possible values:

- "dAtA"** - theoretical calibration („Data Sheet” type calibration) according to data sheet of load cell transducers (strain bridges),
- "rEAL"** - dead weight calibration (entry of values for certain known loads).



„**CALibr**” menu shows option related to selected calibration method only. When dead weight calibration is selected then „**LoAd**” parameter is visible. When theoretical calibration is selected then parameters „**r LoAd**” and „**r out**” are visible in place of „**LoAd**”.

"r LoAd" - Rated Load calibration parameter. This parameter is expressed in **kg** and can be changed in range from 000000 to 999999, making allowance for „**rESOL**” parameter.



In case of connection of two, three or four transducers parameter „**r LoAd**” should be set to arithmetic sum of nominal weights of all the sensors.

"r out" - Rated Output calibration parameter (output value of load cell transducer at nominal load). This parameter is expressed in mV/V and can be set in range from 0.0000 to 1.9999 (when „**rAnGE**” = 2mV/V) or from 0.0000 to 3.9999 (when „**rAnGE**” = 4mV/V).



In case of connection of two, three or four transducers parameter „**r out**” should be set as arithmetic mean of all sensors signals.

"LoAd " - function allowing dead weight calibration. After selection of this function it is necessary to enter some value (expressed in **kg**) and confirm entered value by pressing **[ENTER]** or press **[ESC]** when value needn't to be changed. To cancel calibration press **[ESC]** after questions „**rEADY?**” appear. Pressing **[ENTER]** after „**rEADY?**” appear causes storing current value of input signal. If input signal value exceeds permissible range then calibration fails and message „**Err**” is displayed. Weight is expressed in **kg**, and can be changed in range from 000000 to 999999 making allowance for „**rESOL**” parameter.



Due to measurement precision it is recommended to use weight not less than 2/3 of full scale weight while dead weight calibration. Best results can be obtained after calibration with dead weight equal to maximum expected weight put of the scale.

"S ZERo" - this function allows to storing momentary value as “zero” of recalculation characteristic. Storing is done directly after pressing of **[ENTER]** button.

"Z oFFS" - Zero Offset calibration parameter. This parameter is expressed in **kg** and can be changed in range from 000000 to 999999, making allowance for „**rESOL**” parameter.

"FilTEr" - this parameter defines input signal filtration rate. It can be changed in range from 0 (lowest filtration) to 5 (highest filtration) which corresponds to **26Hz, 17Hz, 8Hz, 4Hz, 1Hz, 0,5Hz**. Bigger filtration level causes slower changes of measurement results because measurements are realised with longer time interval. While fast

changes of input signal (weight) high value of „FiLTeR” can cause degradation of measurement precision.

”S tEST” - this function allows to view transducer signal value expressed in mV/V.

Procedure of theoretical calibration

1. Set parameter „C tYPE” = „dAtA”.
2. Set required measurement displaying resolution (”rESOL” parameter).
3. Set proper working range of measurement input (”rAnGE” parameter).
4. Set required values of parameters „r LoAd” and „r out”.
5. Unload scale (get weight off from a scale if it was loaded).
6. Make zeroing using „S Zero” function.

After this procedure device is ready to work.



If it is impossible to get weight off from a scale if it was loaded then points 5 and 6 can be skipped. Instead it is required to enter known value of the empty scale as an „Z oFFS” parameter.

Procedure of dead weight calibration:

1. Set parameter „C tYPE” = „rEAL”.
2. Set required measurement displaying resolution (”rESOL” parameter).
3. Set proper working range of measurement input (”rAnGE” parameter).
4. Unload scale (get weight off from a scale if it was loaded).
5. Make zeroing using „S Zero” function.
6. Load scale with known weight.
7. Enter the value of known (calibration) weight using „LoAd” function.

After this procedure device is ready to work.

7.3.4. ”OutPUt” menu

This menu contains parameters of analogue output control.



Analogue output can be controlled depend on both present measured value and peak value (if peak detection is enabled).

“OUtmod” - analogue output mode. Depending on version of the device there are following options:

For active current output:

- ”oFF” - current output disabled,
- ”0-20” - current output enabled with 0 ÷ 20 mA mode,
- ”4-20” - current output enabled with 4 ÷ 20 mA mode,
- ”modb” - current output controlled via RS-485 interface.

For passive current output:

- ”oFF” - current output disabled,
- ”4-20” - current output enabled with 4 ÷ 20 mA mode,
- ”modb” - current output controlled via RS-485 interface.

For active voltage output:

- "**oFF**" - voltage output disabled,
- "**0-5**" - voltage output enabled with 0 ÷ 5V mode,
- "**1-5**" - voltage output enabled with 1 ÷ 5V mode,
- "**0-10**" - voltage output enabled with 0 ÷ 10V mode,
- "**2-10**" - voltage output enabled with 2 ÷ 10 V mode,
- "**modb**" - voltage output controlled via RS-485 interface.

"**Source**" - this parameter defines source of signal controlling the analog output, and can be set to one of two values:

"**Gross**" - output is controlled due to gross value of weight,

"**nett**" - output is controlled due to nett value of weight.

"**Out LO**" - this parameter determines the input value for which the output signal is **minimal** (depend of output mode "**Outmod**").

"**Out HI**" - this parameter determines the input value for which the output signal is **maximal** (depend of output mode "**Outmod**").

The analogue output value is calculated due to formula given below:

$$Out = \frac{W - "Out LO"}{"Out HI" - "Out LO"} \times (B - A) + A$$

- where: **W** – displayed value,
Out – analogue output value,
B – higher range limit (20mA / 5V / 10V),
A – lower range limit (0mA / 4mA / 0V / 1V / 2v),



"**Out LO**" parameter can be greater than "**Out HI**". In this case the conversion characteristic is reversed, it means that if input value raises the output value falls.

"**Lo r**", "**Hi r**" - this parameters define the output value range. If calculated output value **Out** exceeds defined range then analogue output generates signal equal to upper or lower border of the defined range. These parameters defines the percentage extension of nominal analogue range (with 0,1% resolution).

Parameter "**Lo r**" defines lower border of the range due to formula:

$Out_{min} = A - (A \times "Lo r" \%)$, where:

A – lower signal value range limit.

This parameter can be set from 0 to 99.9% (for active current output and active voltage output) or from 0 to 29.9% (for passive current output).

Parameter "**Hi r**" defines higher border of the range due to formula:

$Out_{max} = B + (B \times "Hi r" \%)$, where:

B – higher signal value range limit.

This parameter can be set from 0 to 19.9% (for active and passive current output) or from 0 to 9.9% (for active voltage output).

In example on page 42 the procedure of the analogue outputs determining is presented in details.

"AL" - this parameter determines the behaviour of analogue output if any critical situation occurs. According to version of the device, this parameter can be set:

For active current output:

- "noCH"** - current will not change,
- "22.1"** - current will be set to 22.1 mA,
- "3.4"** - current will be set to 3.4 mA,
- "0.0"** - current will be set to 0 mA.

For passive current output:

- "noCH"** - current will not change,
- "22.1"** - current will be set to 22.1 mA,
- "3.4"** - current will be set to 3.4 mA,

For active voltage output:

- "noCH"** - voltage will not change,
- "11.0"** - voltage will be set to 11 V,
- "5.5"** - voltage will be set to 5.5 V,
- "1.2"** - voltage will be set to 1.2 V.
- "0.6"** - voltage will be set to 0.6 V,
- "0.0"** - voltage will be set to 0 V.

When the critical situation goes, the output signal will be set to value calculated due to formulas given above.

If parameter **"Outmod"** is set to **"oFF"**, **"4-20"**, **"0-20"**, **"0-5"**, **"1-5"**, **"0-10"** or **"2-10"** the "critical situation" means that *nominal measurement range* is exceeded.

If parameter **"Outmod"** is set to **"modbus"**, the "critical situation" means communication delay (when no data is received) longer than **"mbtime"** parameter (see **chapter 7.3.10. "rS-485" menu**).



Before turning off the device it is recommended to first disable the current output's power supply, and then the device itself. If the current output is supplied while the device itself is turned off, the output current will be about 27.5 mA.

7.3.5. "button" menu

This menu allows enabling of functions realised by [**>0<**], [**T**] and [**B/N**] buttons.

"b ZErO" - enable of zeroing function - button [**>0<**]:

- "oFF"** - disabled,
- "on"** - enabled.

"b tArE" - enable of tare function - button [**T**]:

- "oFF"** - disabled,
- "on"** - enabled.

"b nett" - enable of presentation mode switching (gross/net) - button[**B/N**]:
 "oFF" - disabled,
 "on" - enabled.

7.3.6. "Pr inP" parameter

This parameter allows enabling of function realised by programmable input.

"diSAbL" - disable programmable input,
"ZEro" - use programmable input to execute zeroing function,
"tArE" - use programmable input to execute tare function,

7.3.7. "HOLd" menu

This menu contains parameters connected with peak detection function. See also full description of the peak detection function in paragraph: **DETECTION OF THE PEAK VALUES**

"modE" - the type of detected changes of the input signal, can be set to values:

"norm" - peaks, peak and next drop of the input signal of value equal at least **"PEA"**,
 "inv" - drops, drop and next peak of the input signal of value equal at least **"PEA"**,

"PEA" - minimal detected signal change classified as peak or drop (see **Figure 6.1**)

"time" - maximum time of displaying of the peak (drop) value, can be set from 0.0 to 19.9 sec, with 0.1 sec. resolution. If „**H diSp**”=**"HOLD"** then setting parameter **"time"**=**0.0** causes holding peak value until **[ESC]** button is pressed. If „**H diSp**”=**"rEAL"** then value **"time"**=**0.0** means no holding.

"H diSp" - type of displayed values:

"rEAL" - current value is displayed,
 "HOLd" - peak (drop) value is displayed,

"H rEL1", **"H rEL2"** - relay/LED outputs (R1,R2) operation mode:

"rEAL" - relay/LED operates depend on the current value,
 "HOLd" - relay/LED operates depend on the peak (drop) value.

"H OutP" - current output operation mode:

"rEAL" - current output operates depend on the current value,
 "HOLd" - current output operates depend on the peak (drop) value.

7.3.8. "briGHt" parameter

This parameter allows user to set bright of the LED display, bright can be set to conventional values from 1 to 8.

7.3.9. "SECUR" menu

This menu contains presets connected with availability of other parameters:

"SEtCod" - user password (4-digits number). If this parameter is set at value **"0000"**, user password is turned off.



If the user do not remember his password, the access to the menu is possible by the "one-use password". To get this password please contact with Marketing Division. "Single use password" can be used only one time, after that it is destroyed. Entering this password causes in clearing of user password, it means sets the user password to „0000“.

The "one-use password" can be used **ONE TIME ONLY**, it is impossible to use it again! The "one-use password" can be restored by Service Division only.

"Acc r1, Acc r2" - this option permits user (**"on"**) or prohibits (**"oFF"**) to modify the thresholds of the relays/LEDs R1, R2 without knowledge about user password.

7.3.10. "rS-485" menu

This menu is connected with RS-485 interface, and sets his properties:

"Addr" - this parameter defines the address of the device, accordingly to Modbus protocol. It can be set in range from 0 to 199. If the value 0 is set then device, responds to frames with address 255 (FFh).

"bAud" - this parameter determines RS-485 interface baud rate. It can be set to one of 8 possible values: **"1200"**, **"2400"**, **"4800"**, **"9600"**, **"19200"**, **"38400"**, **"57600"**, **"115200"**.

"mbAccE" - this parameter sets the access to the configuration registers of the device.
Possible values:

"on" - configuration registers can be set via RS-485 interface,

"oFF" - configuration registers can not be set via RS-485 interface.



The access to registers no 04h and 05h cant be denied by **"mbAccE"** parameter (see: **LIST OF REGISTERS**).

"mbtimeE" - this parameter defines maximal time (sec) between following frames received by the device. If the delay will be greater than the value of **"mbtimeE"** parameter, the relays and the analogue output which are controlled via RS-485 interface, will set to alert state (see **"OUTPut" menu** and **"rELAy1" menu** description). Parameter **"mbtimeE"** can be set to values from 0 to 99 seconds. The value 0 means that the time will be not controlled.

"rESP" - this parameter defines minimal (additional) delay between the Modbus message and the answer of the device (received and sent via RS-485 interface). This additional delay allows the device to work with poor RS-converters which do not works properly on baud rates higher than 19200. This parameter can be set to one of values:

- "Std" - answer as quick as possible, no additional delay
- "10c" } - answer delayed of 10, 20, 50, 100 of 200 chars respectively, where
 "20c" } one character time depends on selected baud rate
 "50c" }
 "100c" }
 "200c" }



In the most cases parameter "rESP" should be set to "Std" (no additional delay). Unfortunately for some third party RS-converters "rESP" should be adjusted experimentally. **Tab.7.2** contains most frequently used values.

"bAud" parameter	"38.4"	"57.6"	"115.2"
"rESP" parameter	"10c"	"20c"	"50c"

Tab.7.2. Settings of "rESP" parameter

7.3.11. "Edit t" parameter

This parameter allows to change the edition mode of numerical parameters:

- "dig" - the change to "by digit" mode,
 "Slid" - slide change mode.

7.3.12. "dEFS" parameter

This setting allows to restore the factory settings of the device. To get the access to this option special password is required: „5465“, next the device displays acknowledge question „SEt?“. Press **[ENTER]** to acknowledge the restoring of factory settings or **[ESC]** to cancel.

7.3.13. "SErv" menu

This menu contains the parameters for authorized service only. To enter this menu proper service password must be entered. Improper settings can causes of damage of the device.

See previous page

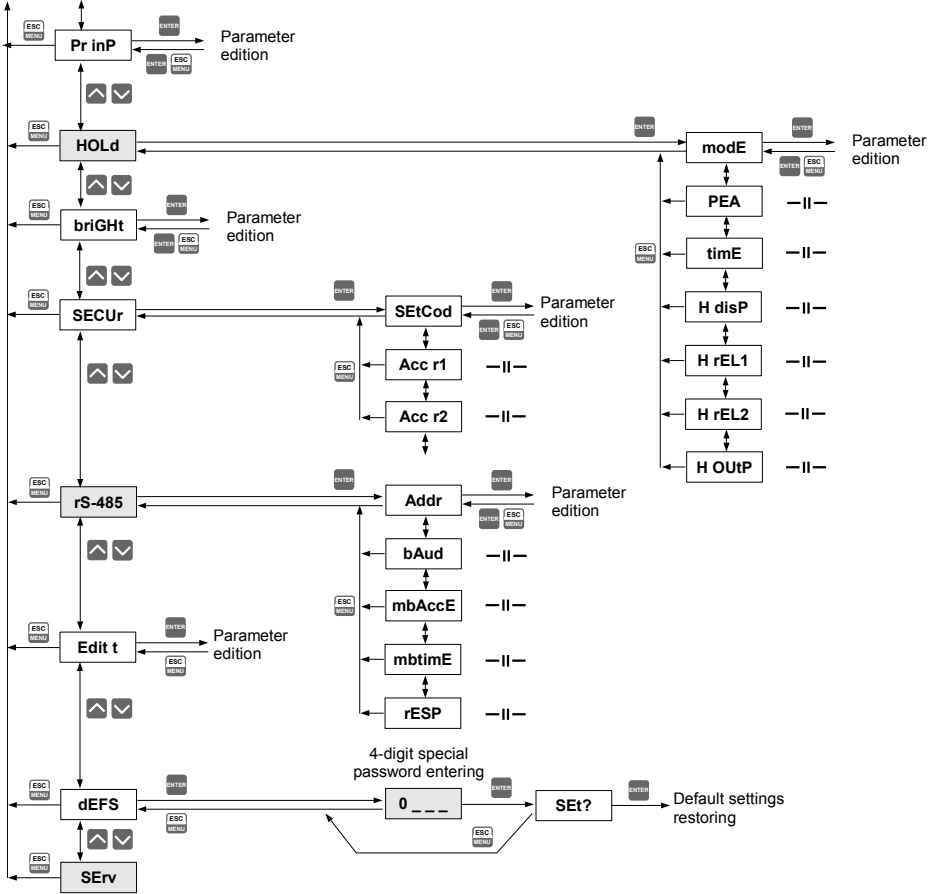

8. OUTPUT VALUE CALCULATION

Lets assume that we have active current output and its parameters are:
 “modE” = “on”, “OUT LO” = 100, “OUT HI” = 200, “Lo r” = 5.0, “Hi r” = 5.0
 Parameters “Lo r” and “Hi r” define working range of current output to 3,8 ÷ 21 mA.
 Output current will be calculated for three displayed values „D”:

a) D = „17.5”

According to formula from page 35:

$$I_{out} = (17.5-10.0) / (20.0-10.0) \times 16 \text{ mA} + 4 \text{ mA} = 0.75 \cdot 16 + 4 = 16 \text{ mA}$$

Calculated I_{out} do not exceeds the output working range (3 - 21 mA).

b) D = „20.5”

According to formula from page 35:

$$I_{out} = (20.5-10.0) / (20.0-10.0) \times 16 \text{ mA} + 4 \text{ mA} = 1.05 \cdot 16 + 4 = 20.08 \text{ mA}$$

Calculated I_{out} do not exceeds the output working range (3 - 21 mA).

c) D = „30.0”

According to formula from page 35:

$$I_{out} = (30.0-10.0) / (20.0-10.0) \times 16 \text{ mA} + 4 \text{ mA} = 2 \cdot 16 + 4 = 36 \text{ mA}$$

Calculated I_{out} exceeds the output working range (3 - 21 mA), so current output will generate current equal to the upper border of range defined by parameter “Lo r” and “Hi r” (it means 21 mA).

9. SIGNALISATION OF ERRORS

Some critical situations are signalised in texts or numbers format (like „Err NN”), where NN denotes error number and can be one of values presented below:

NN	Description	Meaning
16	“ErrC ”	Dead weight calibration error
68	“Short ”	Shortcut on input or resultant impedance of input load cell(s) (tensometer sensor) is to low
70	“OPEn ”	Break of input circuit or incorrect input voltage level
72	“OvEr V”	Exceeding of input voltage permissible range or connectors 30...35 of the tensometer sensor are not connected
73	“OvEr C”	Exceeding of current source maximum load (tensometer sensor overloads measurement input)
74	“tr Err”	Converter (transducer) error – contact with manufacturer's service
75	“no rEF”	No reference voltage or incorrect input voltage level
96	“Lo”	Exceeding of measurement range lower border
160	“Hi”	Exceeding of measurement range upper border
-	“mZ Err”	Manual Zeroing error (function cannot be done)
-	“mt Err”	Manual Tare error (function cannot be done)
-	“-OvEr-”	measured value exceeds the display range (-99999 ÷ 999999)

10. THE MODBUS PROTOCOL HANDLING

Transmission parameters: 1 start bit, 8 data bits, 1 or 2 stop bit (2 bits are send, 1 and 2 bits are accepted when receive), no parity control
 Baud rate: selectable from: 1200 to 115200 bits/second
 Transmission protocol: MODBUS RTU compatible

The device parameters and display value are available via RS-485 interface, as HOLDING-type registers (numeric values are given in U2 code) of Modbus RTU protocol. The registers (or groups of the registers) can be read by 03h function, and wrote by 06h (single registers) or 10h (group of the registers) accordingly to Modbus RTU specification. Maximum group size for 03h and 10h functions can not exceeds 16 registers (for single frame).



The device interprets the broadcast messages, but then do not sends the answers.

10.1. LIST OF REGISTERS

Some parameters are located on two registers (higher word in first register, and lower word in next one). After writing of one of them device controls result of their 32-bit value, and if it is necessary corrects value of second register automatically. If appropriate modification is impossible, both registers stay unaffected and device responds with error code 03h (see: **TRANSMISSION ERRORS DESCRIPTION**).

Register	Write	Range	Register description
01h ¹ 02h ¹	No	-99999 ÷ 999999	Measurement value (no decimal point)
03h	No	0h or error no	The status of the current measurement; 0h - data valid; other values describe errors (see SIGNALISATION OF ERRORS)
04h	No	0 ÷ 2	Decimal point position. The same as 11h register.
05h	Yes	0 ÷ 31	State of the relays, LEDs and programmable input (binary format) (1 - on, 0 - off): 00000000 00fedcba a - relay R1; b - relay R2; c - LED "NET"; d - LED "><"; e - LED ">0<"; f - programmable input; If written, only a , b , bits are important (others are ignored) these bits allows user to control the relays via RS-485 interface
06h ²	Yes	0h ÷ 1800h	State of active current output, expressed in 1/256 mA units – it means that high byte express integer part, and low byte fractional part of desired output current.
	Yes	2CCh+1800h	State of passive current output, expressed in 1/256 mA units – it means that high byte express integer part, and low byte fractional part of desired output current.
	Yes	0h ÷ 1600h	State of active voltage output, expressed in 1/512 V units – it means that high byte express integer part, and low byte fractional part of desired output voltage.
07h ¹ 08h ¹	No	-99999 ÷ 999999	Peak (drop) value (no decimal point)

Register	Write	Range	Register description
09h ¹ 0Ah ¹	No	-99999 ÷ 999999	Gross measurement value (no decimal point)
0Bh ¹ 0Ch ¹	Yes	-99999 ÷ 999999	Nett measurement value (no decimal point). Writing a „0” value causes the execution of the tare function.
Parameters of measurement input calibration			
10h	Yes	0 ÷ 11	“ rESOL ” parameter in “ CALibr ” menu (displaying resolution): 0 - "0.01"; 1 - "0.02"; 2 - "0.05"; 3 - "0.1"; 4 - "0.2"; 5 - "0.5"; 6 - "1"; 7 - "2"; 8 - "5"; 9 - "10"; 10 - "20"; 11 - "50".
11h	No	0 ÷ 2	Decimal point position set by “ rESOL ” parameter in “ CALibr ” menu: 0 - " 0"; 1 - " 0.0"; 2 - " 0.00".
12h	Yes	0 ÷ 1	“ rAnGE ” parameter in “ CALibr ” (measurement range): 0 - "2 mV/V"; 1 - "4 mV/V".
13h	Yes	0 ÷ 1	“ C tYPE ” parameter in “ CALibr ” menu (calibration type): 0 – theoretical calibration; 1 – real load calibration
14h 15h	Yes	0 ÷ 999999	“ r LoAd ” parameter in “ CALibr ” menu, expressed in kg, 0.1kg or 0.01 kg (depending on “ rESOL ” parameter in “ CALibr ” menu)
16h	Yes	0 ÷ 19999	“ r out ” parameter in “ CALibr ” menu (for 2 mV/V range) expressed in 0.0001 mV/V
17h	Yes	0 ÷ 39999	“ r out ” parameter in “ CALibr ” menu (for 4 mV/V range) expressed in 0.0001 mV/V
18h	Yes	0 ÷ 5	“ FilTEr ” parameter in “ CALibr ” menu: 0 – the shortest measurement period; 5 – the longest measurement period;
19h	Yes	0	“ S ZERo ” function in “ CALibr ” menu. After writing „0” value current measurement value is stored as „zero”
1Ah 1Bh	Yes	0 ÷ 99999	“ Z oFFS ” parameter in “ CALibr ” menu, expressed in kg, 0.1kg or 0.01 kg (depending on “ rESOL ” parameter in “ CALibr ” menu)
20h ³	Yes	0 ÷ 199	Device address
21h	No	20E6h	Device identification code (ID)
22h ⁴	Yes	0 ÷ 7	“ bAud ” parameter in “ rs-485 ” menu (baud rate); 0 - 1200 baud; 1 - 2400 baud; 2 - 4800 baud; 3 - 9600 baud; 4 - 19200 baud; 5 - 38400 baud; 6 - 57600 baud; 7 - 115200 baud
23h ⁵	Yes	0 ÷ 1	“ mbAcCE ” parameter in “ rs-485 ” menu (permission to write registers via RS-485 interface); 0 - write denied ; 1 - write allowed
25h	Yes	0 ÷ 5	“ rESP ” parameter in “ rs-485 ” menu (additional response delay); 0 - no additional delay; 1 - “ 10c ” option; 2 - “ 20c ” option; 3 - “ 50c ” option; 4 - “ 100c ” option; 5 - “ 200c ” option;
27h	Yes	0 ÷ 99	“ mbtIME ” parameter in “ rs-485 ” menu (maximum delay between received frames); 0 - no delay checking; 1 ÷ 99 - maximum delay expressed in seconds
28h	Yes	0 ÷ 1	“ AL ” parameter in “ bEEP ” menu: 0 - off; 1 - on

Register	Write	Range	Register description
29h	Yes	0 ÷ 1	"r1" parameter in "bEEP" menu: 0 - off; 1 - on
2Ah	Yes	0 ÷ 1	"r2" parameter in "bEEP" menu: 0 - off; 1 - on
2Dh	Yes	1 ÷ 8	"brighT" parameter (display brightness); 1 - the lowest brightness; 8 - the highest brightness
2Fh	Yes	0 ÷ 1	"Edit" parameter (numerical parameters edit mode); 0 - „dig" mode; 1 - „SLid" mode
Parameters of relay R1 operation			
30h 31h	Yes Yes	-99999 ÷ 999999	"SEt P" parameter in "rELAy1" menu, no decimal point included
32h 33h	Yes Yes	0 ÷ 99999	"HySt" parameter in "rELAy1" menu, no decimal point included
34h	Yes	0 ÷ 5	"modE" parameter in "rELAy1" menu: 0 - "noAct" mode; 1 - "on" mode; 2 - "oFF" mode; 3 - "in" mode; 4 - "out" mode; 5 - "modbuS" mode
35h	Yes	0 ÷ 999	"t on" parameter in "rELAy1" menu, expressed in tenth of seconds or tenth of minutes depend on "unit" parameter
36h	Yes	0 ÷ 999	"t oFF" parameter in "rELAy1" menu, expressed in tenth of seconds or tenth of minutes depend on "unit" parameter
37h	Yes	0 ÷ 1	"unit" parameter in "rELAy1" menu: 0 - seconds; 1 - minutes
38h	Yes	0 ÷ 2	"ALArMS" parameter in "rELAy1" menu: 0 - no changes; 1 - on; 2 - off
39h 3Ah	Yes Yes	-99999 ÷ 999999	"SEt P2" parameter in "rELAy1" menu, no decimal point included
3Bh	Yes	0 ÷ 1	"SouRCE" parameter in "rELAy1" menu (kind of value controlled relay): 0 - "GroSS"; 1 - "nEt"
Parameters of relay R2 operation			
40h 41h	Yes Yes	-99999 ÷ 999999	"SEt P" parameter in "rELAy2" menu, no decimal point included
42h 43h	Yes Yes	0 ÷ 99999	"HySt" parameter in "rELAy2" menu, no decimal point included
44h	Tak	0 ÷ 5	"modE" parameter in "rELAy2" menu: 0 - "noAct" mode; 1 - "on" mode; 2 - "oFF" mode; 3 - "in" mode; 4 - "out" mode; 5 - "modbuS" mode
45h	Yes	0 ÷ 999	"t on" parameter in "rELAy2" menu, expressed in tenth of seconds or tenth of minutes depend on "unit" parameter
46h	Yes	0 ÷ 999	"t oFF" parameter in "rELAy2" menu, expressed in tenth of seconds or tenth of minutes depend on "unit" parameter
47h	Yes	0 ÷ 1	"unit" parameter in "rELAy2" menu: 0 - seconds; 1 - minutes

Register	Write	Range	Register description
48h	Yes	0 ÷ 2	“ ALArms ” parameter in “ rELAY2 ” menu: 0 - no changes; 1 - on; 2 - off
49h 4Ah	Yes Yes	-99999 ÷ 999999	“ SEt P2 ” parameter in “ rELAY2 ” menu, no decimal point included
4Bh	Yes	0 ÷ 1	“ SourCE ” parameter in “ rELAY1 ” menu (kind of value controlled relay): 0 - “GroSS”; 1 - “nEtT”
Configuration of peaks detection function			
70h	Yes	0 ÷ 1	“ modE ” parameter in “ HOLd ” menu (type of detected changes): 0 - peaks; 1 - drops
71h 72h	Yes	0 ÷ 999999	“ PEA ” parameter in “ HOLd ” menu (minimum detectable change, no decimal point included)
73h	Yes	0 ÷ 199	“ timE ” parameter in “ HOLd ” menu, maximum peaks' (or drops') display time expressed in seconds
74h	Yes	0 ÷ 1	“ H diSP ” parameter in “ HOLd ” menu (the type of values displayed on the display): 0 - current measurement value; 1 - peaks (or drops) values
75h	Yes	0 ÷ 1	“ H rEL1 ” parameter in “ HOLd ” menu (the control mode of relay R1 and LED R1): 0 - control depends on current measurement values; 1 - control depends on peaks (or drops) values;
76h	Yes	0 ÷ 1	“ H rEL2 ” parameter in “ HOLd ” menu (the control mode of relay R2 and LED R2): 0 - control depends on current measurement values; 1 - control depends on peaks (or drops) values;
79h	Yes	0 ÷ 1	“ H OUTP ” parameter in “ HOLd ” menu (the control mode of current output): 0 - control depends on current measurement values; 1 - control depends on peaks (or drops) values;
Functions of buttons and programmable input			
80h	Yes	0 ÷ 1	“ b ZErO ” parameter in “ button ” menu (function of zeroing button): 0 - disabled; 1 - enabled
81h	Yes	0 ÷ 1	“ b tArE ” parameter in “ button ” menu (function of tare button): 0 - disabled; 1 - enabled
81h	Yes	0 ÷ 1	“ b nEtT ” parameter in “ button ” menu (function of gross/nett button): 0 - disabled; 1 - enabled
84h	Yes	0 ÷ 2	“ Pr inP ” parameter (function of programmable input): 0 - input disabled; 1 - zeroing function; 2 - tare function
Parameters of analogue output operation			
A0h ²	Yes	0 ÷ 3	“ Omod ” parameter in “ OUTP ” menu (active current output mode) 0 - current output disabled; 1 - current output enabled with 4÷20mA mode; 2 - current output enabled with 0÷20mA mode; 3 - current output controlled via RS-485 interface

Register	Write	Range	Register description
	Yes	0 ÷ 2	“ Omod ” parameter in “ OutP ” menu (passive current output mode) 0 - current output disabled; 1 - current output enabled with 4÷20mA mode; 2 - current output controlled via RS-485 interface
	Yes	0 ÷ 5	“ Omod ” parameter in “ OutP ” menu (active voltage output mode) 0 - voltage output disabled; 1 - voltage output enabled with 0÷5V mode; 2 - voltage output enabled with 1÷5V mode; 3 - voltage output enabled with 0÷10V mode; 4 - voltage output enabled with 2÷10V mode; 5 - voltage output controlled via RS-485 interface
A1h ² A2h ²	Yes	-99999 ÷ 999999	“ Out LO ” parameter in “ OutPut ” menu, no decimal point included
A3h ² A4h ²	Yes	-99999 ÷ 999999	“ Out HI ” parameter in “ OutPut ” menu, no decimal point included
A5h ²	Yes	0 ÷ 999	“ Lo r ” parameter in “ OutP ” menu, for active current output and active voltage output, expressed in 0.1%
	Yes	0 ÷ 299	“ Lo r ” parameter in “ OutP ” menu for passive current output, expressed in 0.1%
A6h ²	Yes	0 ÷ 199	“ Hi r ” parameter in “ OutP ” menu for active and passive current output, expressed in 0.1%
	Yes	0 ÷ 99	“ Hi r ” parameter in “ OutP ” menu for active voltage output, expressed in 0.1%
A7h ²	Yes	0 ÷ 3	“ AL ” parameter in “ OutP ” menu (active current output value on critical exception): 0 - no change; 1 - 22.1 mA; 2 - 3.4 mA; 3 - 0 mA
	Yes	0 ÷ 2	“ AL ” parameter in “ OutP ” menu (passive current output value on critical exception): 0 - no change; 1 - 22.1 mA; 2 - 3.4 mA
	Yes	0 ÷ 5	“ AL ” parameter in “ OutP ” menu (active voltage output value on critical exception): 0 - no change; 1 - 11 V; 2 - 5.5; 3 - 1.2 V; 4 - 0.6 V; 5 - 0 V
A8h ²	Yes	0 ÷ 1	“ SourCE ” parameter in “ OutPut ” menu (kind of value controlled active current output): 0 - “GroSS”; 1 - “nEtt”

- 1 - it is recommended to read these registers simultaneously – in 2-registers frames. If single registers are read, data errors are possible because of changes of read value between successive registers readings.
- 2 - these registers are active only if device is equipped with current or voltage output
- 3 - after writing to register no 20h the device responds with an “old” address in the message.
- 4 - after writing to register no 22h the device responds with the new baud rate.
- 5 - the value of the “**mbAccE**” parameter is also connected to write to this register, so it is possible to block a writes, but impossible to unblock writes via RS-485 interface, The unblocking of the writes is possible from menu level only.

10.2. TRANSMISSION ERRORS DESCRIPTION

If an error occurs while write or read of single register, then the device sends an error code (according to Modbus RTU specifications).

Error codes:

01h - illegal function (only functions 03h, 06h and 10h are available),

02h - illegal register address

03h - illegal data value

08h - no write permission (see: “**mbAccE**” parameter)

While reading of displayed value (registers 01h ÷ 04h) using function 03h (read single register) other error codes can occur. Meaning of such codes is given in chapter **SIGNALISATION OF ERRORS** in details.

10.3. EXAMPLES OF QUERY/ANSWER FRAMES

Examples apply for device with address 1. All values are represent hexadecimal.

Field description:

ADDR Device address on modbus network

FUNC Function code

REG H,L Starting address (address of first register to read/write, Hi and Lo byte)

COUNT H,L No. of registers to read/write (Hi and Lo byte)

BYTE C Data byte count in answer frame

DATA H,L Data byte (Hi and Lo byte)

CRC L,H CRC error check (Hi and Lo byte)

1. Read of the displayed value (measurement) and status, the device address = 01h:

ADDR	FUNC	REG H,L		COUNT H,L		CRC L,H	
01	03	00	01	00	03	54	0B

a) The answer (we assume that the measure result is not out of range):

ADDR	FUNC	BYTE C	DATA H1,L1		DATA H2, L2		DATA H3.L3		CRC L,H	
01	03	06	00	01	86	A0	00	00	2A	B4

DATA H1, L1 - reg. 01h (1 - high word of measurement value)

DATA H2, L2 - reg. 02h (86A0h - low word of measurement value),

DATA H3, L3 - reg. 03h (0 - measurement status).

In this example measurement value is equal 186A0h (100 000 in decimal format).



Decimal point position is not included in measurement value (reg. 01h and 02h).
Decimal point position can be read from reg. 04h.

b) The answer (if an error occur):

ADDR	FUNC	ERROR	CRC L,H	
01	83	40	40	C0

ERROR - error code = 40h, bottom border of the measurement range is exceeded

2. Read of device ID code

ADDR	FUNC	REG H,L		COUNT H,L		CRC L,H	
01	03	00	21	00	01	D4	00

The answer:

ADDR	FUNC	BYTE C	DATA H,L		CRC L,H	
01	03	02	20	E6	20	0E

DATA - identification code (20E6h)

3. Change of the device address from 1 to 2 (write to reg. 20h)

ADDR	FUNC	REG H,L		DATA H,L		CRC L,H	
01	06	00	20	00	02	09	C1

DATA H - 0

DATA L - new device address (2)

The answer (the same as the message):

ADDR	FUNC	REG H,L		DATA H,L		CRC L,H	
01	06	00	20	00	02	09	C1

4. Change of baud rate of all devices connected to the net (BROADCAST message).

ADDR	FUNC	REG H,L		COUNT H,L		CRC L,H	
00	06	00	22	00	04	29	D2

DATA H - 0

DATA L - 4, new baud rate 19200 baud



Device do not reply to BROADCAST-type messages.

5. Try to write improper data to register (register 04h):

ADDR	FUNC	REG H,L		DATA H,L		CRC L,H	
01	06	00	04	00	10	C9	C7

DATA H, L written value (10h = 16) out of allowable range (0 ÷ 2)

Device response (with exception code 03h):

ADDR	FUNC	ERR	CRC L,H	
01	86	03	09	C1



There is no full implementation of the Modbus Protocol in the device. The functions presented above are available only.

11. DEFAULT AND USER'S SETTINGS LIST

Parameter	Description	Default value	User's value	Desc. page
Parameters of relay R1 operation ("rELAy1" menu)				
SourCE	Kind of value controlled relay state	GroSS		30
SEt P	Relay first threshold	20.0		30
SEt P2	Relay second threshold	30.0		30
HYSt	Hysteresis of relay	0.0		30
modE	Operation mode of relay	on		30
t on	Turn on delay of relay	0.0 (sec.)		31
t oFF	Turn off delay of relay	0.0 (sec.)		31
unit	Unit of "t on", "toFF" parameters of relay	SEC		31
ALArmS	Reaction for critical situation of relay	oFF		32
Parameters of relay R2 operation ("rELAy2" menu)				
SourCE	Kind of value controlled relay state	GroSS		30
SEt P	Relay first threshold	150.0		30
SEt P2	Relay second threshold	300.0		30
HYSt	Hysteresis of relay	0.0		30
modE	Operation mode of relay	on		30
t on	Turn on delay of relay	0.0 (sec.)		31
t oFF	Turn off delay of relay	0.0 (sec.)		31
unit	Unit of "t on", "toFF" parameters of relay	SEC		31
ALArmS	Reaction for critical situation of relay	oFF		32
Activation of acoustic signal ("bEEPEr" menu)				
AL	Activation of acoustic signal by critical situation	oFF		32
r1	Activation of acoustic signal by relay R1	oFF		32
r2	Activation of acoustic signal by relay R2	oFF		32
Calibration of measurement input ("CALibr" menu)				
rESOL	Displaying resolution	0.1		33
rAnGE	Measurement range	4 mV/V		32
C tYPE	Calibration type	dAtA		33
r LoAd	Rated Load parameter	100.0		33
r out	Rated Output parameter	2.0000		33
LoAd	Load value of dead weight calibration	100.0		33

Parameter	Description	Default value	User's value	Desc. page
Z oFFS	Zero Offset parameter	0.0		33
FILtEr	Measurements filtration rate	4		33
Active current output configuration ("OUTP" menu)				
Omod	Active current output mode	0-20 (mA)		34
OUTL	Display value for 0 mA or 4 mA current output	0.0		35
OUTH	Display value for 20 mA current output	100.0		35
Lo r	Extension of the bottom of the nominal output range	5.0 (%)		35
Hi r	Extension of the top of the nominal output range	5.0 (%)		35
AL	Current output value on critical exception	22.1 (mA)		36
Passive current output configuration ("OUTP" menu)				
Omod	Passive current output mode	4-20 (mA)		34
OUTL	Display value for 4 mA current output	0.0		35
OUTH	Display value for 20 mA current output	100.0		35
Lo r	Extension of the bottom of the nominal output range	5.0 (%)		35
Hi r	Extension of the top of the nominal output range	5.0 (%)		35
AL	Current output value on critical exception	22.1 (mA)		36
Active voltage output configuration ("OUTP" menu)				
Omod	Active voltage output mode	0-10 (V)		34
OUTL	Display value for 0 V, 1 V or 2 V voltage output	0.0		35
OUTH	Display value for 5 V or 10 V voltage output	100.0		35
Lo r	Extension of the bottom of the nominal output range	5.0 (%)		35
Hi r	Extension of the top of the nominal output range	5.0 (%)		35
AL	Voltage output value on critical exception	11.0 (V)		36
Front panel buttons configuration ("button" menu)				
b ZErO	Zeroing button	oFF		36
b tArE	Tare button	oFF		36
b nEtt	Gross/nett display mode switching button	oFF		37
Configuration of programmable input				
Pr inP	Function of programmable input	diSABL		37
Configuration of peaks detection function ("HOLd" menu)				
modE	Kind of detected changes	norm		37
PEA	Minimum detected change	0.0		37

<i>Parameter</i>	<i>Description</i>	<i>Default value</i>	<i>User's value</i>	<i>Desc. page</i>
timE	Maximum time of peak displaying	0.0 (sec.)		37
H diSP	The type of displayed value	rEAL		37
H rEL1	Source of relay R1, and LED R1 control	rEAL		37
H rEL2	Source of relay R2, and LED R2 control	rEAL		37
H OUtP	Source of current output control	rEAL		37
Display parameters				
briGHT	Display brightness	bri 6		37
Settings of access to the configuration parameters ("SECUR" menu)				
Acc r1	Permission to changes of relay R1 threshold without of the user password knowledge	on		38
Acc r2	Permission to changes of relay R2 threshold without of the user password knowledge	on		38
RS 485 interface configuration (menu "rS-485")				
Addr	Device address	0		38
bAud	Baud rate	9600 (b./sec.)		38
mbAccE	Permission to changes of configuration registers	on		38
mbtimE	Maximum delay between received messages	0		38
rESP	Additional delay of answer transmission	Std		38
Configuration of numerical parameters edition				
Edit t	Numerical parameters edit mode	dig		39

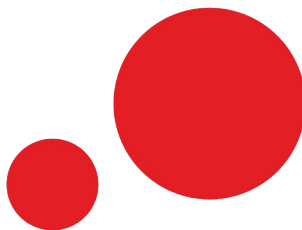

**SIMEX Sp. z o.o.
ul. Wielopole 11
80-556 Gdańsk
Poland**

**tel.: (+48 58) 762-07-77
fax: (+48 58) 762-07-70**

**<http://www.simex.pl>
e-mail: info@simex.pl**