

# User manual

# LIQUID SENSOR

# DRS-30x

- Input type: push-pull
- reference electrode available



Read the user's manual carefully before starting to use the unit or software.  
Producer reserves the right to implement changes without prior notice.

## **CONTENTS**

<b>1. BASIC REQUIREMENTS AND USER SAFETY.....</b>	<b>3</b>
<b>2. GENERAL CHARACTERISTICS.....</b>	<b>4</b>
<b>3. TECHNICAL DATA.....</b>	<b>4</b>
<b>4. DEVICE INSTALLATION.....</b>	<b>5</b>
4.1. UNPACKING.....	5
4.2. ASSEMBLY.....	5
4.3. CONNECTION METHOD.....	7
4.4. MAINTENANCE.....	10

### **Explanation of symbols used in the manual:**



- This symbol denotes especially important guidelines concerning the installation and operation of the device. Not complying with the guidelines denoted by this symbol may cause an accident, damage or equipment destruction.

**IF THE DEVICE IS NOT USED ACCORDING TO THE MANUAL THE USER IS RESPONSIBLE FOR POSSIBLE DAMAGES.**



- This symbol denotes especially important characteristics of the unit. Read any information regarding this symbol carefully

## **1. BASIC REQUIREMENTS AND USER SAFETY**



- **The manufacturer is not responsible for any damages caused by inappropriate installation, not maintaining the proper environmental conditions and using the unit contrary to its assignment.**
- Installation should be conducted by qualified personnel . During installation all available safety requirements should be considered. The fitter is responsible for executing the installation according to this manual, local safety and EMC regulations.
- The unit must be properly set-up, according to the application. Incorrect configuration can cause defective operation, which can lead to unit damage or an accident.
- **If in the case of a unit malfunction there is a risk of a serious threat to the safety of people or property additional, independent systems and solutions to prevent such a threat must be used.**
- The unit must be switched off and disconnected from the power supply prior to starting installation of troubleshooting (in the case of malfunction).
- Neighbouring and connected equipment must meet the appropriate standards and regulations concerning safety and be equipped with adequate overvoltage and interference filters.
- **Do not attempt to disassemble, repair or modify the unit yourself. The unit has no user serviceable parts. Defective units must be disconnected and submitted for repairs at an authorized service centre.**



- Do not use the unit in areas threatened with excessive shocks, vibrations, dust, humidity, corrosive gasses and oils.
- Do not use the unit in areas where there is risk of explosions.
- Make sure that the ambient temperature (e.g. inside the control box) does not exceed the recommended values. In such cases forced cooling of the unit must be considered (e.g. by using a ventilator).



**The unit is designed for operation in an industrial environment and must not be used in a household environment or similar.**

## **2. GENERAL CHARACTERISTICS**

Liquid sensor type **DRS-30x** is designed for conducted liquid presence detection. Parameters of the detector have been fixed to allow detection of actual presence of liquid on its electrodes and to be resistant for low impedance conducted surfaces (e. g. wet fingers). Additional reference electrode prevents detector against false signalling when liquid covers its surface only. PUSH-PULL output gives an opportunity for connection either to devices equipped with direct or inverse logic inputs. Wide range of supply voltage (12 - 30V DC) and operation temperatures (-40°C ÷ +85°C) allow to use the sensor in most systems (e. g. pump dry run detection, full tank detection etc.)

### **Approximate resistivity of water**

<b>Kind of water</b>	from water supply system	potable water	mineral water	distilled water
<b>resistivity</b>	0.5 ÷ 5kΩ/cm	1 ÷ 8kΩ/cm	2 ÷ 5kΩ/cm	50 ÷ 200kΩ/cm

## **3. TECHNICAL DATA**

Power supply voltage	12V... <b>24</b> ...30V DC
Current consumption	about 5mA (+ output load )
Output	PUSH-PULL
Output max. load	50mA (sink and source)
Output delay	< 100ms
Detection threshold	12kΩ ± 20%
Protection level	IP 67
Material of electrodes	Stainless still, acid resistant
Filling material	polyurethane
Mounting method	thread
Connection	cable 4 x 0.5, polyurethane
Cable length	1...3 m (depending on device version)
Housing type	gland M20x1,5 LAPKABEL
Housing dimensions	28 x 33 mm, thread M20x1,5x9
Weight	50 g
Operating temperature	-40°C do +85°C
Storage temperature	-40°C do +85°C



**This is a class A unit. In housing or a similar area it can cause radio frequency interference. In such cases the user can be requested to use appropriate preventive measures.**

## **4. DEVICE INSTALLATION**

The unit has been designed and manufactured in a way assuring a high level of user safety and resistance to interference occurring in a typical industrial environment. In order to take full advantage of these characteristics installation of the unit must be conducted correctly and according to the local regulations.



- Installation should be conducted by qualified personnel .
- Read the basic safety requirements on page 3 prior to starting the installation.
- All installation works must be conducted with a disconnected power supply.

### **4.1. UNPACKING**

After removing the unit from the protective packaging, check for transportation damage. Any transportation damage must be immediately reported to the carrier. Also, write down the unit serial number on the housing and report the damage to the manufacturer.

Attached with the unit please find:

- user's manual,
- warranty,

### **4.2. ASSEMBLY**

DRS sensor should be installed directly into side wall of a container. Application of 10 mm length threaded flange (M20x1,5) is allowed. The installation should assure free access of water (or other conductive liquid) to the electrodes, however it is required to preserve minimum distance between electrodes and walls of container (pipe).

Teflon tape is recommended for sealing.



- Disconnect the power supply prior to starting assembly.
- Check the correctness of the performed connections prior to switching the unit on.

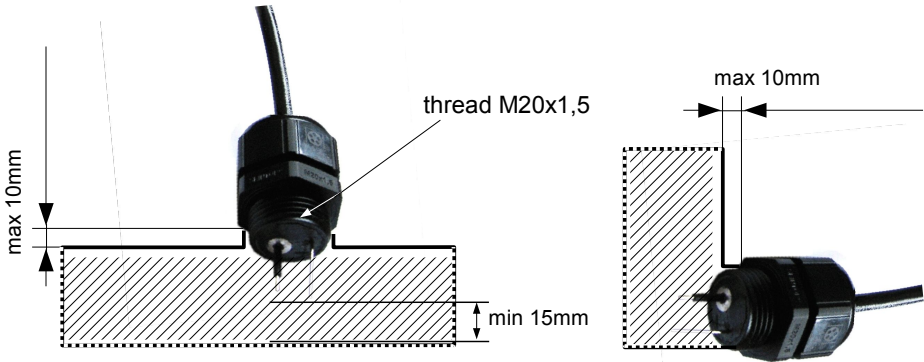

Figure 4.1. Installation



The device should not be used while strong vibrations occurs, and must not be used for security systems.

The sensor can be installed in all positions, but recommended positions are shown in figure below. Avoid positions causing damages and accumulation of sediments on electrodes.

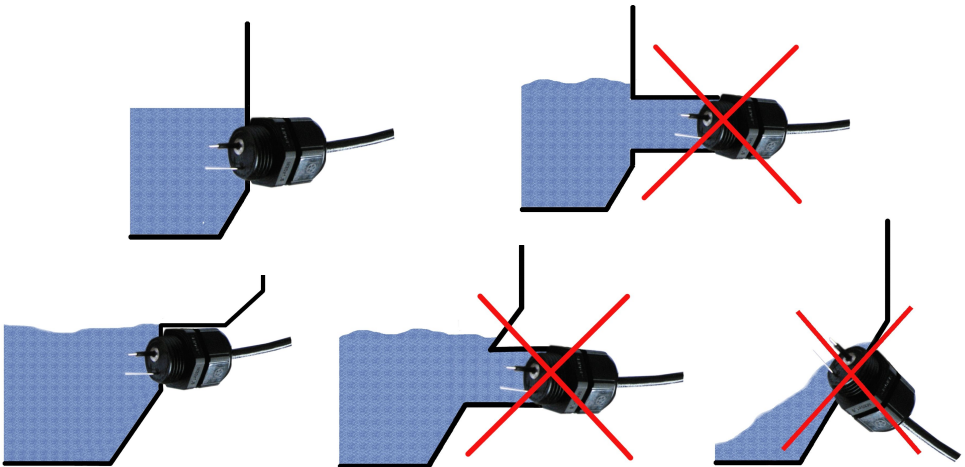

Figure 4.2. Example positions of sensor installation.

### **4.3. CONNECTION METHOD**

#### **Caution**



- Installation should be conducted by qualified personnel . During installation all available safety requirements should be considered. The fitter is responsible for executing the installation according to this manual, local safety and EMC regulations.
- **This device is not fully isolated. Pay special attention to installation method, while the device is installed outside. User should use proper measures, guarantee safety while storm lighting e.g. safety equipment like: separators, isolators etc. Due to the risk of electric shock, additional PE connection should be made between the device and the rest of construction details.**
- Wiring must meet appropriate standards and local regulations and laws.
- Tighten the clamping screws. The recommended tightening torque is 0.5 Nm. Loose screws can cause fire or defective operation. Over tightening can lead to damaging the connections inside the units and breaking the thread.
- In some cases use additional preventive measures (covers, roofing, etc.) to avoid the unit against mechanical damages. Carelessly executed assembly can increase the risk of electric shock.

**Due to possible significant interference in industrial installations appropriate measures assuring correct operation of the unit must be applied. To avoid the unit of improper indications keep recommendations listed below.**

- Avoid common (parallel) leading of signal cables and transmission cables together with power supply cables and cables controlling induction loads (e.g. contactors). Such cables should cross at a right angle.
- Contactor coils and induction loads should be equipped with anti-interference protection systems, e.g. RC-type.
- In the case of magnetically induced interference the use of twisted couples of signal cables (so-called “spirals”) is recommended. The spiral (best if shielded) must be used with RS-485 serial transmission connections.

**Connection method:**

The sensor is equipped with connection cable 4x0,5 with polyurethane insulation. If cable of a factory is to short its extension is allowed, but total length of wires should not exceed 3m.

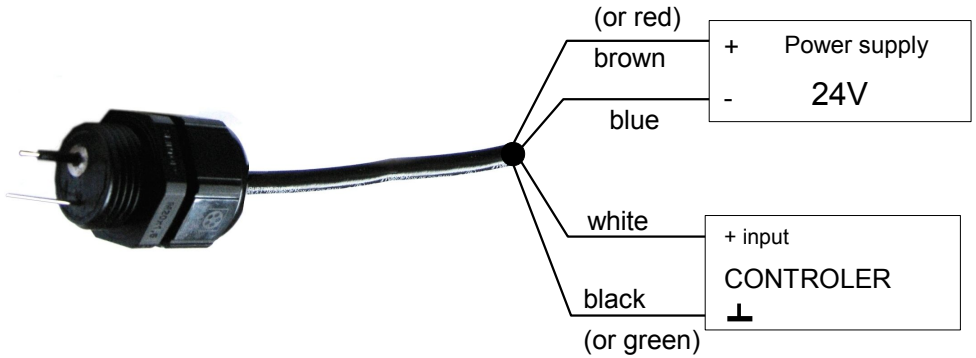
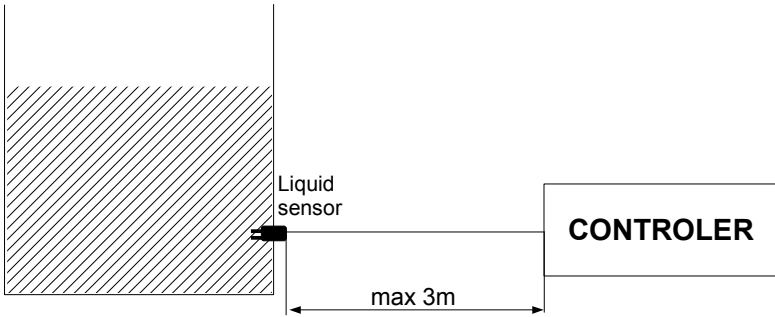

Figure 4.3. Connection

Examples of application are shown in figures Figure 4.4 and 4.5.



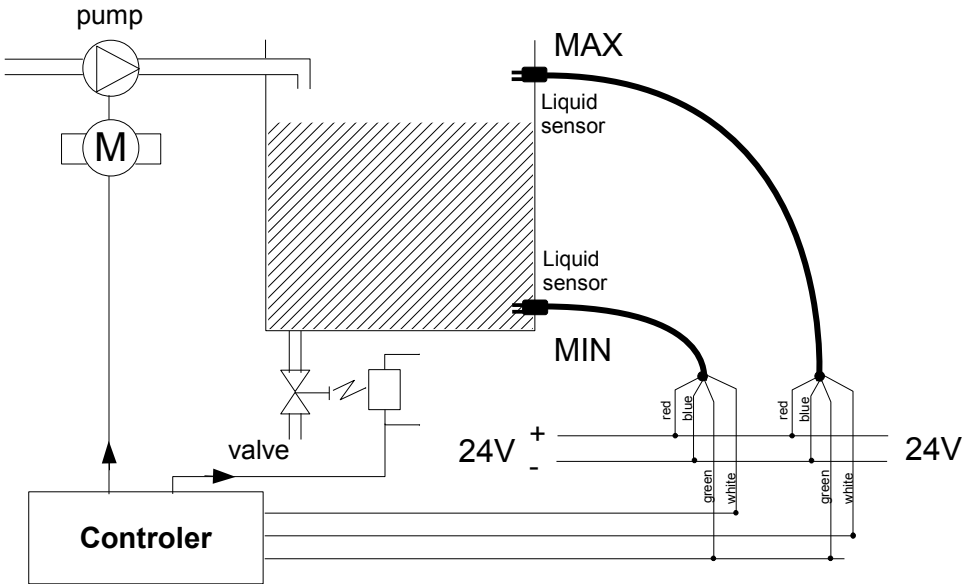

Figure 4.4. Example application of liquid sensor. Control of filling and emptying of an container.

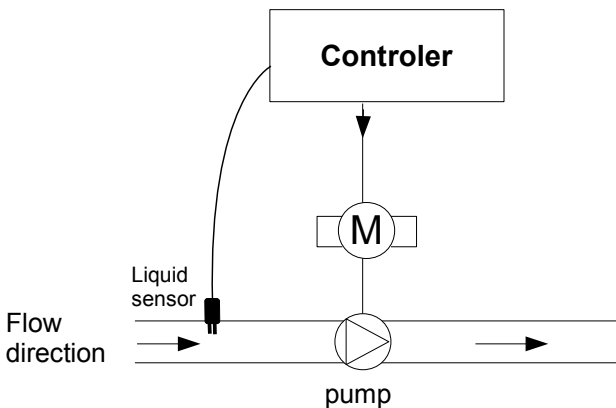

Figure 4.5. Example application of liquid sensor. Pump dry run protection.

#### **4.4. MAINTENANCE**

The unit does not have any internal replaceable components available to the user. Pay attention to the ambient temperature in the room where the unit is operating. Excessively high temperatures cause faster ageing of the internal components and shorten the fault-free time of unit operation.

In cases where the unit gets dirty do not clean with solvents. For cleaning use warm water with small amount of detergent or in the case of more significant contamination ethyl or isopropyl alcohol.



Using any other agents can cause permanent damage to the housing.



Product marked with this symbol should not be placed in municipal waste. Please check local regulations for disposal and electronic products.



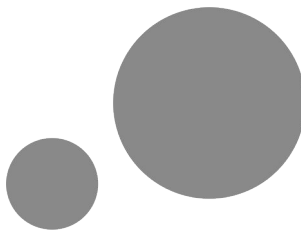

**SIMEX Sp. z o.o.  
ul. Wielopole 7  
80-556 Gdańsk  
Poland**

**tel.: (+48 58) 762-07-77  
fax: (+48 58) 762-07-70**

**<http://www.simex.pl>  
e-mail: [info@simex.pl](mailto:info@simex.pl)**